

# Simply precise

## Electrical drum scales with display

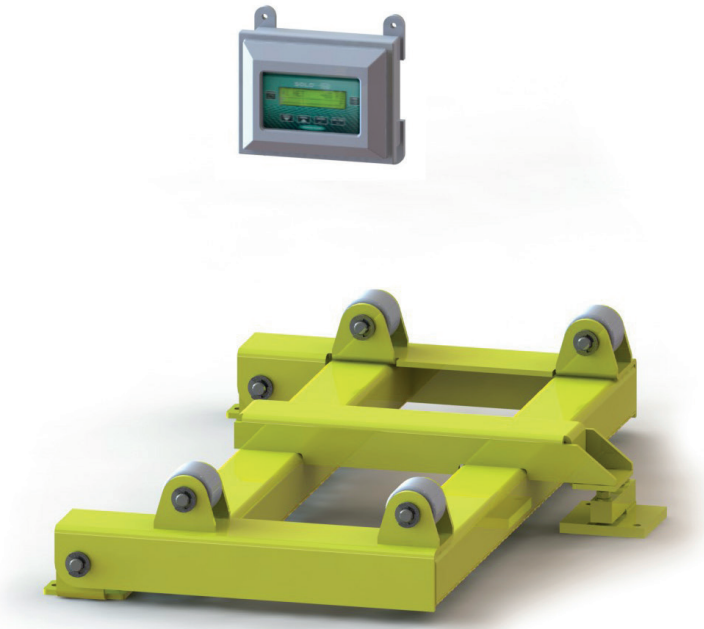

### Safe storage

The electrical scales with digital display makes it easy to determine and display the weight of horizontally positioned drums. A steel weighing frame with polyester coating provides protection from corrosion and safe positioning of the drums. Anchor bolts fix the steel frame simply and securely on a level base. PVC rollers allow the easy movement of any drum into a position where the feed pipe stands vertically in the drum.

### Results clearly displayed

The stainless steel weighing cell provides precise and reproducible measurement results on the digital display. The filling quantity for either one or two drums is determined, depending on the version of the weighing frame. The digital display is on the wall close to the weighing frame and the volume or weight of the contents of the drum can be selected for display on the easy-to-read screen either numerically or as a bar graph.

Depending on the type of digital display, the filling quantity of a single drum or a single group of drums can be displayed and this can be alternated (manually or automatically) or alternatively the filling quantity of both drums or groups of drums can be displayed at the same time. Also depending on the type of digital display, either one or two limit switches and alarm relays are available.

### Functions

- Electronic weighing cell with digital display
- Weighing range 0-2000 kg per weighing cell
- Measuring accuracy 0.1 – 0.25% of the final value
- Filling quantity displayed in litres or kilograms
- IP67 (NEMA 4X) housings
- Clearly arranged display
- With zero and tare adjustment

### Technical data

Weighing range	kg	0 – 2000
Weighing cell precision		0.1 – 0.25 % of the final value
Digital display operating voltage		110 – 240 VAC, 50/60 Hz, 5W
Length of signal line	m	10
Contact load rating for limit switches		2 A for 30 VAC 0.5 A for 120 VAC
Housing protection class		IP67 (NEMA 4X)
Ambient temperature	°C	0 – 50
Weight	Weighing frame	kg 60 (single frame), 120 (double frame)
	Digital display	kg 7
Dimensions of chlorine drums	mm	Ø 750 – 860, L=1200

## Model variants

Product	Signal inputs	Signal outputs
Drum scales for 1 drum with single frame	1	1 x 4 – 20 mA, 1 x relay
Drum scales for 2 drums with double frame		
Drum scales for 2 drums with single frame	2	2 x 4 – 20 mA, 2 x relay
Drum scales for 4 drums with double frame		

## Scope of delivery

The drum scales are supplied with:

- Weighing frame with weighing cell and 10m cable
- Digital display
- Assembly accessories for weighing frame and digital display
- Operating instructions

## Dimensions

Drum scales for 1 drum  
All dimensions in mm

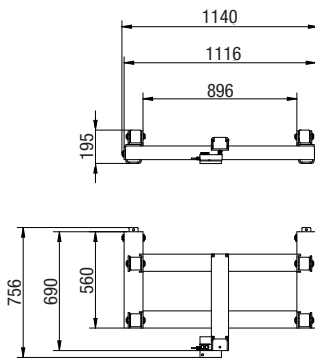

Digital display  
All dimensions in mm

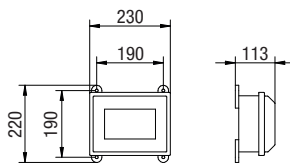

Drum scales for 2 drums  
All dimensions in mm

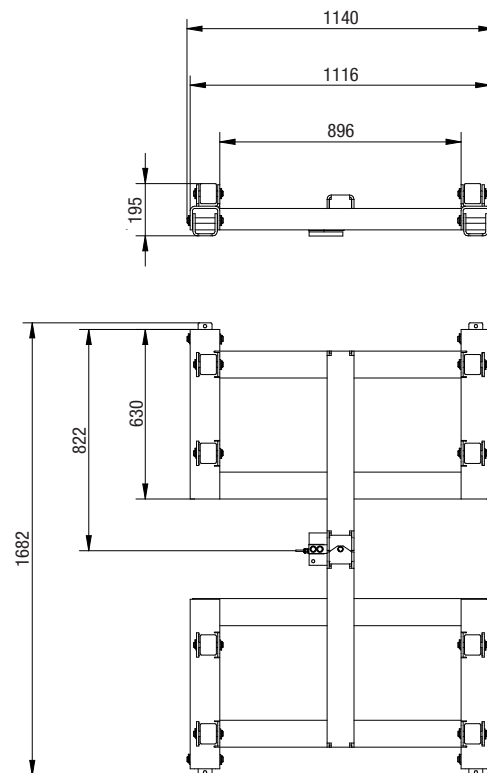

## Accessories

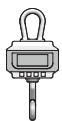

### Crane scale with battery and battery charger

Weighing range 0 – 3000 kg max. load: 3750 kg, with infra-red control system, Display resolution 1 kg



### Trunnion

For the storage of chlorine drums

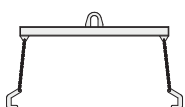

### Crane cross beam

For safe transportation of chlorine drums, max. hoisting load 2000 kg