

A measured step forward

Dosing pumps and accessories

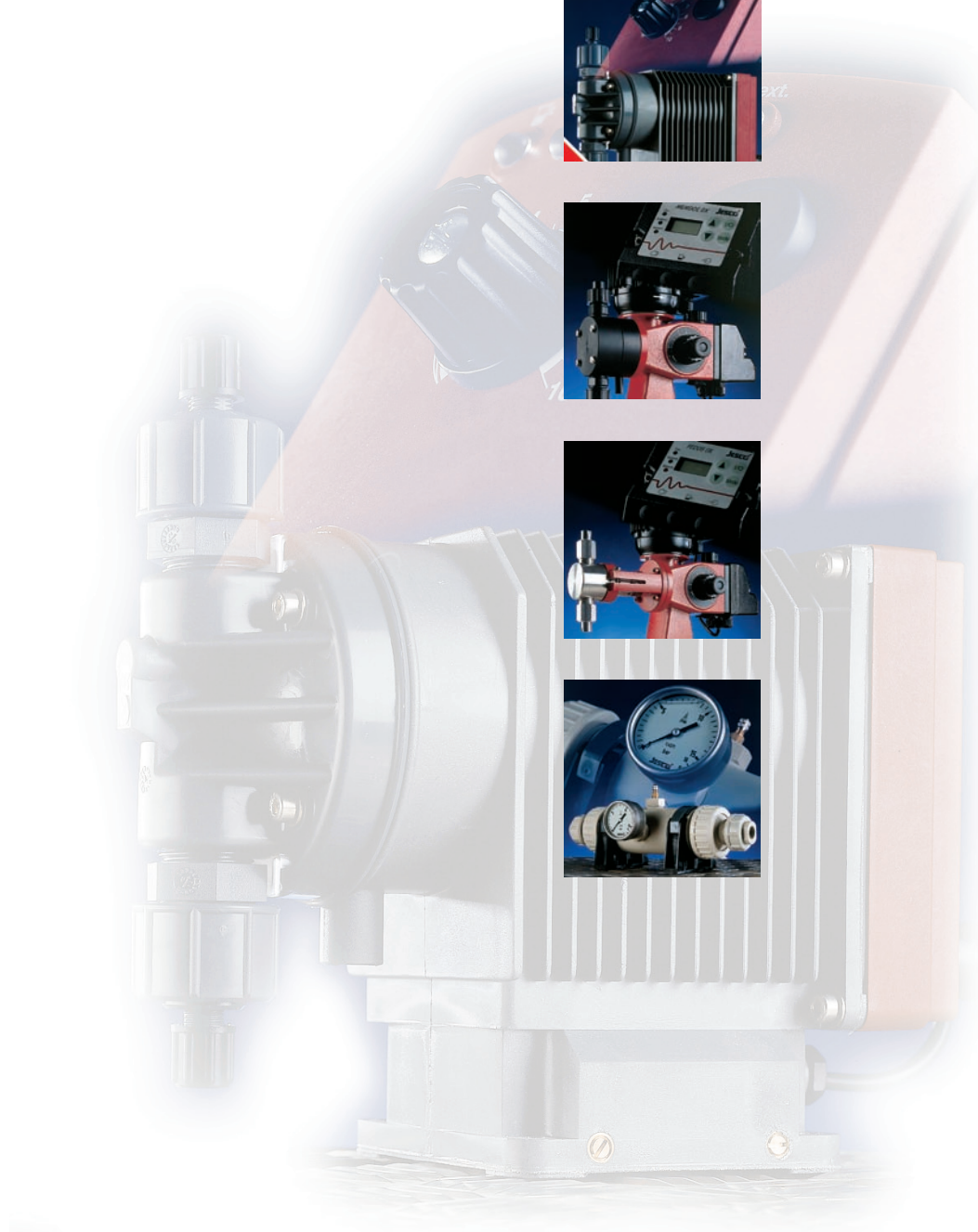
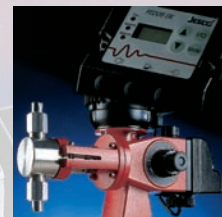

And what can we do for you?

Drop by drop or with maximum capacity, at tropical temperatures and even this possibly in a really “caustic” environment: The demands on dosing pumps being as variable as the application as the possibilities and tasks themselves, Lutz-Jesco offers individual solutions for each field of application. The extensive product program ranges from the low-cost precisely operating **solenoid-driven dosing pump** to the “heavy-duty” **motor-driven diaphragm dosing pump** and the **piston dosing pump** for high pressures up to 400 bar, and last but not least, to the **peristaltic pump** for low pressures. All of them dosing liquids of differing viscosities, mostly chemically aggressive and toxic, sometimes even abrasive or effervescent.

Thought out to the last detail: The accessories program of Lutz-Jesco

Even the best dosing pump can still be improved – namely by the right technical periphery, which, in fact, is the reason for the particularly extensive **accessories program** of Lutz-Jesco. It converts your dosing pump into an efficient dosing system. Should you have any additional requests: We always find a solution.



Lutz-Jesco dosing pumps

A comprehensive range



Diaphragm dosing pumps

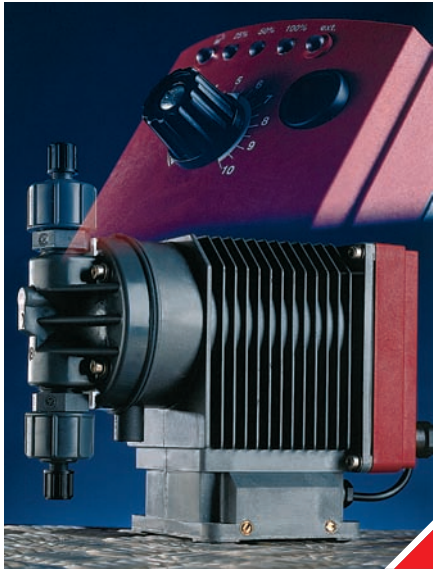

Diaphragm dosing pumps

are leakage-free and especially suitable for high corrosive or toxic media. Depending on the gear type, the diaphragm can be used at pressures of up to 16 bar. As a standard, diaphragm dosing pumps are fitted with a separation chamber, which in the event of a diaphragm failure due to wear, prevents the medium from flooding the pump itself or other system components. Leakage is routed through an outlet pipe to a collection tank. The diaphragms are PTFE-Elastomer compounds, on the medium side. The largest diaphragm pump, type GMR, has a hydraulically actuated double-diaphragm system.

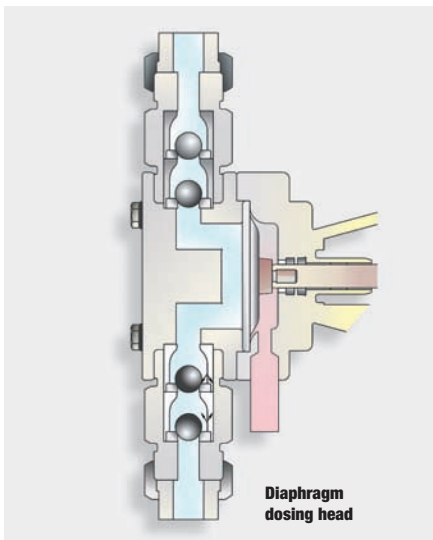

Solenoid-driven diaphragm dosing pumps

are fitted with a powerful solenoid drive. The flow rate per stroke is infinitely variable.

In short

- Capacity range 0.1 to 115 l/h, at up to 16 bar
- Simple but long-lived design
- Suitable for aggressive and toxic media
- Usable at ambient temperatures of up to 45 °C
- Internal stroke rate adjustment and external pacing
- Double-ball check valves for highest accuracy
- Intelligent control

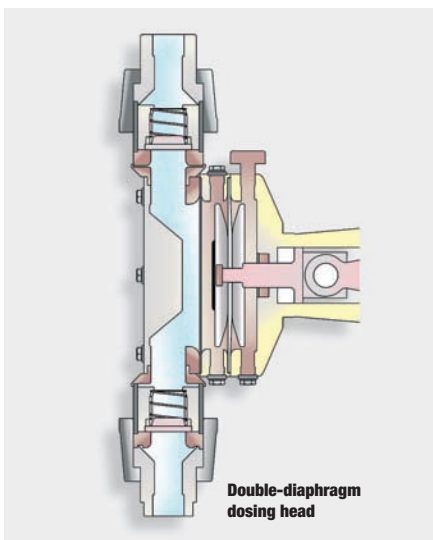

Motor-driven diaphragm dosing pumps have a tappet drive with a continuously adjustable stroke length from 0 to 100%. MEMDOS GMR have a crankshaft assembly.

In short

- Capacity range 3 to 4,000 l/h, at up to 10 bar
- Viscosities up to 3,000 mPa*s
- PTFE diaphragm
- Tappet drive
- Manual and automatic servo capacity adjustment
- Wide range of materials
- Double-diaphragm system optional

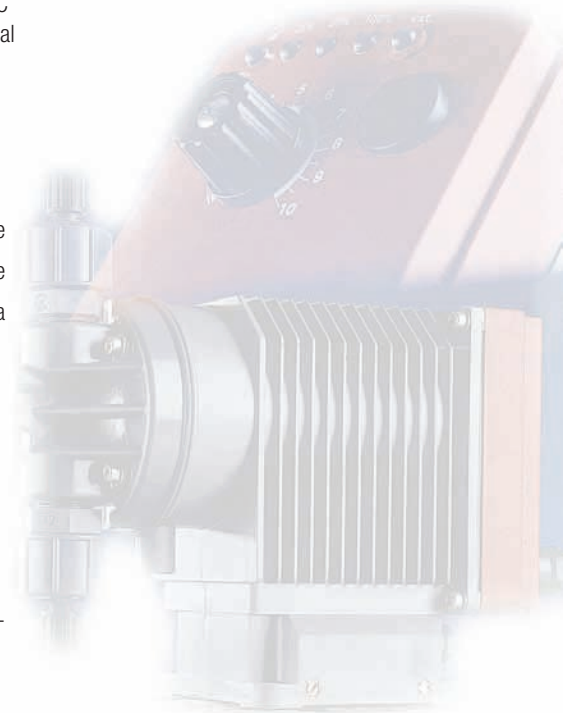

Solenoid-driven diaphragm dosing pumps

MAGDOS LB, MAGDOS LT

Pump model	Flow rate at max. back pressure			Stroke rate strokes/min	Diaphragm Ø mm	Suction lift m wc	Weight approx. kg
	bar	l/h	ml/stroke				
MAGDOS LB							
LB 05	16	0.36	0.05	120	24	5	3
LB 1	16	0.75	0.05	250	24	5	3
LB 2	16	1.9	0.20	160	33	3	3
LB 4	16	3.4	0.31	180	33	3	3
LB 6	8	6.2	0.57	180	39	2	3
LB 10	6	9.0	0.83	180	39	2	3
LB 15	3	13.0	0.86	250	39	2	3



Pump model	Electrical data				
	Supply	Current	Power	Protection class	Insulation class
MAGDOS LB					
LB 05...LB 15	1~ 110...240 V, 50/60 Hz	4 A	18 W	IP 65	F

- Infinitely variable stroke frequency from 0...100%
- Plug & Play dosing pump with wide range power supply unit
- Dosing head with automatic dosing head ventilation in PVC, PP, PVDF
- Mounting on wall or floor without bracket
- Calibration functionality for the adjustment of the capacity

Pump model	Flow rate at max. back pressure			Stroke rate strokes/min	Diaphragm Ø mm	Suction lift m wc	Weight approx. kg
	bar	l/h	ml/stroke				
MAGDOS LT							
LT 02	12	0.14	0.03	80	32	3.0	2.7
LT 06	16	0.48	0.1	80	32	3.0	2.7
LT 1	16	0.9	0.19	80	32	3.0	2.7
LT 3	16	1.6	0.33	80	32	3.0	2.7
LT 4	12	3.3	0.69	80	32	3.0	2.7
LT 6	10	5.2	0.72	120	32	3.0	2.7
LT 10	8	7.9	1.1	120	38	2.0	2.7
LT 17	3	13.5	1.88	120	52	1.2	2.7



Pump model	Electrical data				
	Supply	Current	Power	Protection class	Insulation class
MAGDOS LT					
LT 02...LT 17	1~ 230 V, 50/60 Hz	2.9 A	30 W	IP 65	F

- Stroke length adjustable 0...100%
- Stroke rate adjustment 25, 50, 100%
- External pacing with the same maximum stroke rate (e.g. water meter contacts)
- Connection for low level control
- CSA-certificate pumps for 230 V, 115 V
- 24 V DC optional



Solenoid-driven diaphragm dosing pumps

MAGDOS DE/DX



Pump model	Flow rate at max. back pressure			Stroke rate strokes/min	Diaphragm Ø mm	Suction lift m wc	Weight approx. kg
	bar	l/h	ml/stroke				
MAGDOS DE/DX							
DE/DX 01	10.0	0.1	0.016	100	20	3.0	2.9
DE/DX 03	6.0	0.46	0.077	100	32	3.0	2.9
DE/DX 07	10.0	0.72	0.12	100	32	3.0	2.9
DE/DX 2	10.0	1.86	0.31	100	32	3.0	2.9
DE/DX 4	10.0	3.9	0.65	100	32	3.0	2.9
DE/DX 8	10.0	6.0	1.0	100	38	2.0	2.9
DE/DX 12	4.0	12.0	2.0	100	52	1.2	2.9
DE/DX 20	10.0	20.2	4.8	70	64	1.2	10.5
DE/DX 40	4.0	50.4	12.0	70	90	1.2	12.5
DE/DX 100	1.5	115.0	27.5	70	120	1.2	12.5

Pump model	Electrical data				
	Supply	Current	Power	Protection class	Insulation class
MAGDOS DE/DX					
DE/DX 01...2	1~ 230 V, 50/60 Hz	1.5 A	21 W	IP 65	F
DE/DX 4...12	1~ 230 V, 50/60 Hz	2.3 A	30 W	IP 65	F
DE/DX 20...100	1~ 230 V, 50/60 Hz	4.1 A	70 W	IP 65	F

- Stroke length adjustable 0...100%
- Stroke length adjustable:
DE/DX 01...12: at up to 0...100/min.
DE/DX 20...100: at up to 0...70/min.
- Changeover function to external pacing (e.g. water meter contacts)
DE/DX 01...12: at up to 100 strokes/min.
DE/DX 20...100: at up to 70 strokes/min.
- Connection for level control with alert alarm
- Pulse and level input physically separated
- With MAGDOS DX, pulse multiplication and division at ratios of 1, 2, 4, 8, 16, 32, 64 and changeover function to external pacing by 0(4)...20 mA
- As an option, both versions are available with warning alarm relay and digital display
- CSA-certificate pumps for 115 V
- DE/DX 2 also available for 16 bar



Motor-driven diaphragm dosing pumps

MINIDOS A, MIDIDOS E

Pump model	Flow rate at max. back pressure			Stroke rate strokes/min	Diaphragm Ø mm	Suction lift m wc	Weight approx. kg
	bar	l/h	ml/stroke				
MINIDOS A							
A 3	10	3.2	1.5	36	38	5.0	4.4
A 5	10	6.4	1.5	72	38	5.0	4.4
A 8	10	8.0	1.5	90	38	5.0	4.4
A 14	10	14.0	2.6	90	52	5.0	4.4
A 24	10	24.0	2.6	138	52	5.0	4.4
A 40	5	39.0	4.7	138	64	2.5	4.7
Pump model	Electrical data						
	Supply	Power	Speed	Protection class	Insulation class		
MINIDOS A							
A 3, 8, 14	3~ 230/400 V, 50 Hz	0.03 kW	1,420 min ⁻¹	IP 55	F		
A 5, 24, 40	3~ 230/400 V, 50 Hz	0.05 kW	2,880 min ⁻¹	IP 55	F		

- Other voltages optional (also single phase)
- Pump is lubricated for long service life
- Cost-efficient
- Compact design



Pump model	Flow rate at max. back pressure			Stroke rate strokes/min	Diaphragm Ø mm	Suction lift m wc	Weight approx. kg
	bar	l/h	ml/stroke				
MIDIDOS E							
E 24	10	24	8.5	48	64	7	7
E 48	10	48	8.5	96	64	7	7
E 72	6	80	8.5	142	64	7	7
E 120	4	114	20.8	96	90	3	8
Pump model	Electrical data						
	Supply	Power	Speed	Protection class	Insulation class		
MIDIDOS E							
E 24...E 120	3~ 230/400 V, 50 Hz	0.05 kW	1,440 min ⁻¹	IP 55	F		

- Manually adjustable stroke lengths from 0...100%
- Gear parts and storage are lubricated for life
- It is possible to operate on alternating voltage
- Gearbox with one-level worm-wheel gear-ratio



Motor-driven diaphragm dosing pumps

MEMDOS E/DX



Pump model MEMDOS E/DX	Flow rate at max. back pressure			Stroke rate ml/stroke strokes/min	Diaphragm Ø mm	Suction lift m wc	Weight		
	bar	l/h					E	DX	
		(50 Hz)	(60 Hz)						
E/DX 4	10	4.0	4.8	2.6	26**	52	9.0	7.4	8.0
E/DX 8	10	7.5	9.0	2.6	48**	52	9.0	7.4	8.0
E/DX 15	10	15.0	18.0	2.6	95**	52	9.0	7.4	8.0
E/DX 25/26*	10	23.0	23.0	2.6	142***	52	9.0	7.4	8.0
E/DX 50	10	48.0	57.6	8.5	95**	64	8.0	9.6	9.2
E/DX 75/76*	10	72.0	72.0	8.5	142***	64	8.0	9.6	9.2
E/DX 110	5	107.0	128.4	19.0	95**	90	7.0	10.2	9.2
E/DX 150/156*	4	160.0	160.0	19.0	142***	90	7.0	10.2	9.2
E/DX 160	10	156.0	187.2	36.5	71**	120	6.0	18.0	18.2
E/DX 200	10	208.0	249.6	36.5	95**	120	6.0	18.0	22.0
E/DX 260	10	263.0	-	36.5	120**	120	6.0	18.0	22.0
E/DX 300	8	292.0	350.4	51.2	95**	150	4.4	19.0	26.0
E/DX 380	6	393.0	-	54.5	120**	150	4.5	19.0	26.0

Pump model MEMDOS E/DX	Electrical data				
	Supply	Power	Speed	Protection class	Insulation class
E 4...E 50	3~ 230/400 V, 50 Hz	0.05 kW	1,420 min ⁻¹	IP 55	F
E 75...E 150	3~ 230/400 V, 50 Hz	0.25 kW	1,420 min ⁻¹	IP 55	F
E 160...E 380	3~ 230/400 V, 50 Hz	0.37 kW	1,420 min ⁻¹	IP 55	F
DX 4...DX 25	1~ 230 V, 50 Hz	0.05 kW	1,420 min ⁻¹	IP 55	F
DX 50...DX 150	1~ 230 V, 50 Hz	0.12 kW	1,420 min ⁻¹	IP 55	F
DX 160...DX 380	1~ 230 V, 50 Hz	0.37 kW	1,420 min ⁻¹	IP 55	F

- * 60 Hz version
- ** at 50 Hz
- *** at 50/60 Hz

- CSA-certificate pumps for 115 V
- Other motor types upon request
- Only MEMDOS E in ATEX design available



Motor-driven diaphragm dosing pumps

MEMDOS MR, MEMDOS GMR

Pump model	Flow rate at max. back pressure			Stroke rate strokes/min	Diaphragm Ø mm	Suction lift m wc	Weight ca. kg
	bar	l/h	ml/stroke				
MEMDOS MR							
MR 400	5	440	165	47	185	2	38
MR 600	5	620	165	70	185	2	38
MR 980	4	990	165	101	185	2	38
Pump model	Electrical data						
	MEMDOS MR	Supply	Power	Speed	Protection class	Insulation class	
MR 400...MR 980	3~ 230/400 V, 50 Hz	0.55 kW (*0.75 kW)	1,410 min ⁻¹	IP 55	F		



upon request

- Other motor types optional
- Twin head pumps available

* in case of frequency inverter operation and as standard for MR 980

Drive by infinitely variable speed transmission gear

Direct motor drive by 3-phase motor or D.C. motor at 2,850 min⁻¹

Pump model	Drive by infinitely variable speed transmission gear			Direct motor drive by 3-phase motor or D.C. motor at 2,850 min ⁻¹			Suction lift m wc	Weight approx. kg
	Flow rate at max. back pressure		Stroke frequency	Flow rate at max. back pressure		*Stroke frequency		
MEMDOS GMR	bar	l/h	min ⁻¹	bar	l/h	min ⁻¹		
GMR 2000	4	350...2,100	11...72	4	1,850	58	1.2	145
GMR 3000	3	530...3,150	11...72	3	2,750	58	1.2	165
GMR 4000	2	700...4,200	11...72	2	3,800	58	1.2	165
Pump model	Electrical data							
	MEMDOS GMR	Supply	Power	Speed	Protection class	Insulation class		
GMR 2000...4000	3~ 230/400 V, 50 Hz	2.2 kW	1,410 or 2,850 min ⁻¹	IP 55	F			

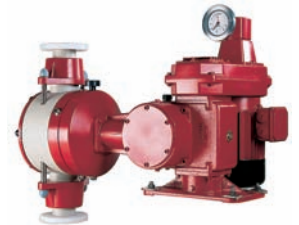

* in order to achieve a higher or lower output, thyristor controllers can be used for D.C. motors and frequency inverters for 3-phase motors

- Other motor types upon request
- Twin head pumps available

Piston dosing pumps

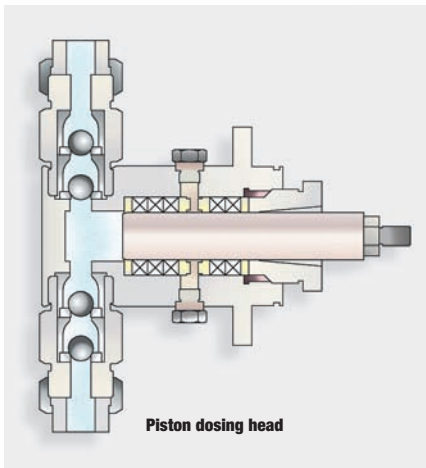

Piston dosing pumps

are especially precise dosing devices and independent of the back pressure. The dosing capacity changes in proportion to the stroke length and can be reproduced, even if very small quantities are required. Therefore double or multiple-head piston pumps are particularly suitable for precise mixing of different components (media) at a freely settable, constant ratio. By using external paced motor speed the pump capacity can be varied infinitely between 5 and 100 % while the ratio remains constant. Heated heads avoid solidifying difficult media. To prevent media leaks and to protect the packings and pistons against abrasive media, flushing lanterns are integrated (FEDOS E/DX optional).

In short

- Capacity range 0.1 to 4,200 l/h, at up to 400 bar
- Tappet drive with easy-to-operate capacity adjustment (FEDOS, REKOS)
- KARDOS with linear amplitude adjustment
- Reliable and proven hydraulic part
- Ceramic and stainless steel piston
- Flushing lantern as standard equipment
- Also suitable for frequency converter operation
- Intelligence due to different operating modes
- Easy and intuitive to operate

Piston dosing pumps

FEDOS E/DX, REKOS KR

Pump model FEDOS E/DX	Flow rate at max. back pressure			Stroke rate strokes/min	Piston Ø mm	Suction lift m wc	Weight approx. kg	
	*bar	l/h (50 Hz)	ml/stroke (60 Hz)					
E/DX 01**	100	0.17	0.20	0.11	26	4	8	11
E/DX 03**	100	0.31	0.37	0.11	48	4	8	11
E/DX 06**	100	0.63	0.76	0.11	95	4	8	11
E/DX 1	100	1.42	1.70	0.25	95	6	8	11
E/DX 2	100	2.13	2.13	0.25	142	6	8	16
E/DX 5	100	4.8	4.8	0.56	142	9	8	16
E/DX 8	80	8.5	8.5	1.0	142	12	8	16
E/DX 17	40	17.0	17.0	2.0	142	17	8	16
E/DX 30	25	31.5	31.5	3.7	142	23	8	16



upon request

Pump model FEDOS E/DX	Electrical data				
	Supply	Power	Speed	Protection class	Insulation class
E 01...E 2	3~ 230/400 V, 50 Hz	0.05 kW	1,420 min ⁻¹	IP 55	F
E 5...E 30	3~ 230/400 V, 50 Hz	0.25 kW	1,420 min ⁻¹	IP 55	F
DX 01...DX 30	1~ 230 V, 50 Hz	0.12 kW	1,420 min ⁻¹	IP 55	F

* standard packings max. pressure 40 bar

** optional up to 200 bar

Pump model REKOS KR	Flow rate at max. back pressure			Stroke rate strokes/min	Piston Ø mm	Suction lift m wc	Weight approx. kg
	*bar	l/h	ml/stroke				
KR 8	200	9	1.5	100	8	8.0	32
KR 20	190	20	3.4	100	12	8.0	32
KR 30	130	31	5.3	100	15	8.0	32
KR 40	95	40	6.8	100	17	8.0	32
KR 75	50	75	12.5	100	23	8.0	32
KR 125	30	125	21.2	100	30	5.0	36
KR 180	20	180	30.5	100	36	5.0	36
KR 295	12	295	50.0	100	46	5.0	36
KR 420	10	420	71.3	100	55	1.2	36
KR 725	5	725	122.0	100	72	1.2	42



Pump model REKOS KR	Electrical data				
	Supply	Power	Speed	Protection class	Insulation class
KR 8...KR 725	3~ 230/400 V, 50 Hz	0.55 kW, (**0.75 kW)	1,410 min ⁻¹	IP 55	F

* standard packings max. pressure 40 bar

• Other motor types upon request

** for frequency inverter operation

Piston dosing pumps

KARDOS KN, KARDOS N



Pump model	Flow rate at max. back pressure			Stroke rate strokes/min	Piston Ø mm	Suction lift m wc	Weight approx. kg
	*bar	l/h	ml/stroke				
KARDOS KN							
KN 10	400	9.9	1.5	110	8	8	52
KN 23	250	22.0	3.4	110	12	8	52
KN 35	160	35.0	5.3	110	15	8	52
KN 45	125	45.0	6.8	110	17	8	52
KN 85	65	82.0	12.5	110	23	8	52
KN 150	40	140.0	21.2	110	30	8	56
KN 210	25	200.0	30.5	110	36	8	56
KN 350	16	325.0	50.0	110	46	8	56
KN 500	11	465.0	71.3	110	55	8	56
Pump model	Electrical data						
KARDOS KN	Supply	Power	Speed	Protection class	Insulation class		
KN 10...KN 500	3~ 230/400 V, 50 Hz	0.55 kW, 0.75 kW, **1.1 kW	1,410 min ⁻¹	IP 55	F		

* standard packings max. pressure 40 bar
 ** depending on back pressure

• Other motor types upon request
 • Multiple-head pumps optional



Pump model	Flow rate at max. back pressure			Stroke rate strokes/min	Piston Ø mm	Suction lift m wc	Weight approx. kg
	*bar	l/h	ml/stroke				
KARDOS N							
N 16	400.0	15	2.5	97	8	8	102
N 56	325.0	53	8.8	97	15	8	102
N 130	130.0	125	20.7	97	23	8	113
N 320	52.0	306	51.0	97	36	8	113
N 750	24.0	715	119.0	97	55	8	131
N 1300	13.0	1,225	204.0	97	72	5	135
N 2500	6.5	2,400	392.0	97	100	5	143
N 4200	3.0	4,100	716.0	97	135	5	177
Pump model	Electrical data						
KARDOS N	Supply	Power	Speed	Protection class	Insulation class		
N 16...N 4200	3~ 230/400 V, 50 Hz	0.55 kW, 0.75 kW, 1.1 kW, 1.5 kW, **2.2 kW	1,410 min ⁻¹	IP 55	F		

* standard packings max. pressure 40 bar
 ** depending on back pressure

• Other motor types upon request
 • Multiple-head pumps optional

Double-diaphragm system

To increase safety against leakage in the case of a diaphragm rupture due to wear and to be able to signalise diaphragm ruptures, hydraulically coupled double-diaphragms can be used (available for sizes from diaphragm diameter 69 mm to 185 mm).

ATE electrical stroke length adjustment

by infinitely adjustable servomotor. With this additional equipment dosing pumps are remotely adjustable, in automatic control systems, closed loops, compound loops.



MEMDOS E with ATE-servomotor and double-diaphragm system

Piston-diaphragm system

For corrosive and abrasive media, which have to be dosed against higher pressures than 16 bar piston pumps can be fitted with a piston-diaphragm system. The KMS system combines the advantages of leakage-free diaphragm dosing pumps and precise piston dosing pumps and thus ensures reliable dosing.

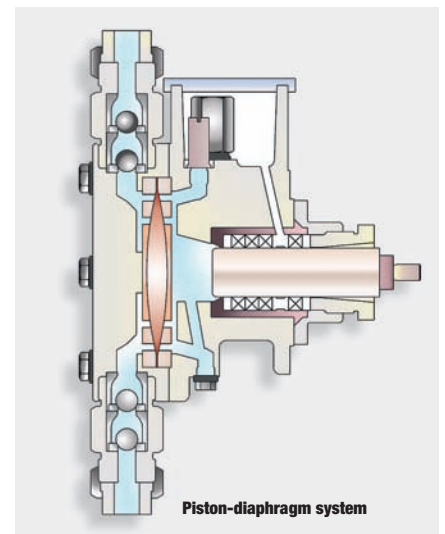

Piston-diaphragm system

Peristaltic pumps



Peristaltic pumps

are the simplest types of dosing pumps. They are used in the field of water treatment whenever low pulsation dosing is required at low pressure. The peristaltic pumps are characterized by insensitivity to vapor locks in the medium. With their rotary displacement body, they are very maintenance-friendly and allow optimal dosing at low back-pressures for simple applications. Typical applications include the dosing of sodium hypochlorite, hydrogen peroxide and hydrochloric acid as well as the dosing of e.g. flocculants or cleaning agents.

In short

- Capacity range 0.4 to 6.6 l/h, at 1.5 bar
- Insensitivity to vapor locks in the medium
- Rotor supported on two sides
- Spring-loaded pressure rollers
- Hose change without tools
- Mounting on profile rails (with peristaltic pump 2.8 l/h)
- Easy to operate and maintain



Peristaltic pumps

Peristaltic pump 2.8 l/h, EASYDOS Peristaltic

Pump model	Flow rate at max. back pressure		Speed min ⁻¹	Suction lift m wc	Weight approx. kg
	bar	l/h			
Peristaltic pump 2.8 l/h	1.5	2.8	30	3	0.75
Pump model	Electrical data				
	Supply	Power	Protection class	Insulation class	
Peristaltic pump 2.8 l/h	1~ 230 V, 50 Hz	5 VA	IP 65	F	



- Hose change without tools
- Mounting on profile rails, even several nest to each other
- Rotor supported on two sides

Pump model	Flow rate at max. back pressure		Speed min ⁻¹	Suction lift m wc	Weight approx. kg
	bar	l/h			
EASYDOS Peristaltic					
Peristaltic 0.4	1.5	0.4	20	1.7	2
Peristaltic 1.4	1.5	1.4	20	1.7	2
Peristaltic 3.4	1.5	3.4	51	1.7	2
Peristaltic 6.6	1.5	6.6	51	1.7	2
Pump model	Electrical data				
	Supply	Power	Protection class	Insulation class	
EASYDOS Peristaltic					
Peristaltic 0.4...1.4	1~ 230 V, 50/60 Hz	16 VA	IP 65	F	
Peristaltic 3.4...6.6	1~ 230 V, 50/60 Hz	16 VA	IP 65	F	



- Splash-proof plastic housing with a powdery epoxy resin coat

Accessories



Accessories

Lutz-Jesco stands out for its broad and fully developed product program for dosing liquids, gases and solids. In addition measuring & control equipment and an extensive range of accessories allow the completion of the dosing installations and the integration in existing processes. Compact dosing systems and products made to the customer's specification are also available.

In short

- Available in all standard materials
- Perfectly user-friendly
- Increases the dosing accuracy
- Simplifies the handling
- Improves the working reliability
- For an optimum automation level



Chemical feed system

Chemical feed systems are especially suitable for dosing:

sodium hypochlorite, flocculants, softeners, cleaning agents, acids, caustics, etc.

Fields of application:

- Water works
- Potable water treatment systems
- Swimming pools
- Feed water systems
- Sewage treatment plants
- Chemical industry
- Process water

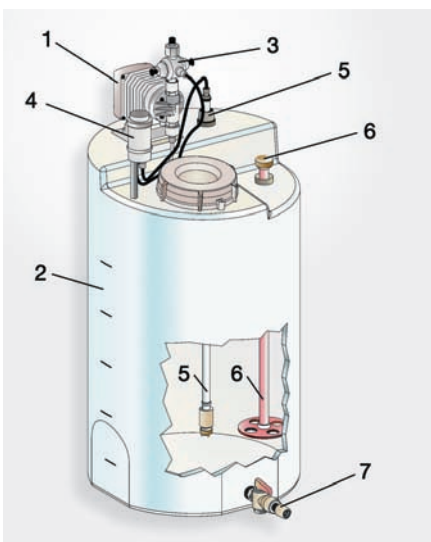

A complete chemical feed system consist of:

- Diaphragm or piston dosing pump
- Tank
- Armatures, e.g. hand mixer, back pressure regulating valve, pulsation dampener, injection fitting. The polyethylene tanks are available from 45 l to 1,000 l.

1. Dosing pump
2. Tank
3. PENTABLOC
4. Priming aid
5. Suction line
6. Hand mixer
7. Drain

Optional water inlet via solenoid valve

Schematic diagram of a typical chemical feed system

Pulsation dampener PDS

The use of PDS inline pulsation dampeners is a simple but effective way to reduce pressure fluctuations to a harmless level so that pump and system are protected. As no T-piece is required to install Lutz-Jesco inline pulsation dampeners, dampening is more effective. The pulsation dampener can be

mounted on the discharge and the suction side. The function is based on the conversion of energy due to compression and expansion of a gas cushion.



Suction controller SDR - safe and precise dosing

The SDR suction controller is a spring-loaded diaphragm valve which is opened by the force of the pump suction pressure. Thus it is ensured that no medium flows if the pump is not working or cannot produce a vacuum because of a line rupture. The

suction controller is mounted on the suction side of dosing pumps and offers a lot of advantages to the user due to its effective design.



Multifunction valve PENTABLOC - compact safety

The accuracy of diaphragm dosing pumps is affected by numerous system conditions. Therefore the PENTABLOC combines all five functions necessary to ensure accurate and safe operation of small

capacity dosing pumps: back pressure, antisiphon, safety relief, pressure relief and dosing monitoring.



Electrical degassing device GAS-EX

Dosing pumps with low flow rates of up to 10 l/h often work imprecisely or must be vented manually if larger amounts of gas or air have entered the dosing head. The GAS-EX degassing device ensures that the pump is automatically vented in

easy selectable intervals. The design has an optimized clearance value so that even small pumps (0.1 l/h) will re-attain full operating pressure right after venting and the flow rate can be maintained.



Accessories



Flow sensor FLOWCON

The FLOWCON flow sensor has been designed especially for applications, where pulsating flow below 50 l/h has to be monitored. Not only the function of the dosing pump itself but also the flow rate is supervised. For electronic evaluation, a PLC

available on site, or an electronic unit developed by Lutz-Jesco for this purpose is used.



Priming aids ASH and AHP

All brands of dosing pumps with low flow rates per stroke often have difficulties in priming. Priming becomes easy by using Lutz-Jesco priming aids, because the dosing head is supplied directly with liquid. Possibly occurring gas is collected in the priming aid. The special feature of the AHP priming

aid is its integrated pumping device which allows to pump the gas out and refill the reservoir without opening it. Thus spilling of possibly dangerous chemicals is avoided.



Back pressure regulating valve and pressure relief valve (BPRV, PRV) and valve assembly

Depending on the application BPRV/PRV are used to increase the dosing accuracy and to protect the pump and system against excessive pressure. Back pressure regulating valves are required if the dosing pump delivers against a fluctuating system

pressure or into a pressureless system. Pressure relief valves prevent an unadmissibly high pressure increase on the discharge side of the dosing pump (safety valve).



Leakage probe - to keep an eye on leakage

The leakage probe is a control armature and is used for a leakage message at conductive media. In case of a diaphragm rupture the escape medium goes through the probe. To amplify the signal, a level relay is used. If necessary the level relay shuts

down the dosing pump or only a message takes place. The leakage probe can also be retro-fitted on existing pumps.

Injection fittings

Injection fittings are functional armatures which help to inject the chemical delivered by the dosing pumps into the system to be treated. They avoid the backflow from the process pipe into the

injection pipe. They consist of an injection pipe and one or two non-return valve as well as a shutoff valve and/or flange connection, if required.



Suction line, suction line for transport-containers, level control

Suction lines are userfriendly assemblies to connect the suction side of the dosing pump easily to the chemical tank. They are available as flexible and rigid version, the length is adjustable. Sophisticated versions are equipped with integrated

level controls as a protection against dry operation (separate level controls are also available). Special suction lines are available for transport containers.



Electric agitator JR and hand mixer

Agitators are useful armatures in order to mix or dissolve the media to be dosed homogeneously. For example suspensions must be circulated permanently or at least periodically so that distribution of the substance remains homogeneous. For

occasional and simple mixing manually operated mixers are recommended. For essential continuous mixing transaction and automatic operation electric agitators complete the program.





Metering pumps, accessories chlorine gas technology, measuring and control technology, centrifugal pumps, disinfection systems and plant engineering and construction



Products for swimming pool water disinfection based on brine-electrolysis, domestic water systems technology



Lutz-Jesco GmbH
Am Bostelberge 19 • D-30900 Wedemark
www.lutz-jesco.de



Tap and tank pumps, flow meters, double diaphragm pumps, centrifugal pumps



Lutz Pumpen GmbH
P.O. Box 1462 • D-97864 Wertheim
www.lutz-pumpen.de

Head office
Lutz-Jesco GmbH
Am Bostelberge 19
30900 Wedemark
Germany

Tel.: +49 5130 5802-0
Fax: +49 5130 580268

E-mail: info@lutz-jesco.com
Internet: www.lutz-jesco.de

Hungary
Lutz-Jesco Üzletág
Vasvári P. u. 9.
9024 Győr
Hungary

Tel.: +36 96 523046
Fax: +36 96 523047

E-mail: info@lutz-jesco.hu
Internet: www.lutz-jesco.hu

Austria
Lutz-Jesco GmbH
Aredstraße 7/2
2544 Leobersdorf
Austria

Tel.: +43 2256 62180
Fax: +43 2256 6218062

E-mail: info@lutz-jesco.at
Internet: www.lutz-jesco.at

Netherlands
Lutz-Jesco Nederland B.V.
Nijverheidstraat 14 C
2984 AH Ridderkerk
Netherlands

Tel.: +31 180 499460
Fax: +31 180 497516

E-mail: info@lutz-jesco.nl
Internet: www.lutz-jesco.nl

Great Britain
Lutz-Jesco (GB) Ltd.
Gateway Estate
West Midlands Freeport
Birmingham B26 3QD
Great Britain

Tel.: +44 121 782 2662
Fax: +44 121 782 2680

E-mail: info@lutz-jesco.co.uk
Internet: www.lutz-jesco.co.uk

USA
Lutz-JESCO America Corp.
55 Bernar Park
Rochester, N.Y. 14624
USA

Tel.: +1 585 426-0990
Fax: +1 585 426-4025

E-mail: mail@jescoamerica.com
Internet: www.jescoamerica.com

East Asia
Lutz-Jesco East Asia Sdn Bhd
6 Jalan Saudagar U1/16
Hicom Glenmarie Industrial Park
40150 Shah Alam/ Selangor
Malaysia

Tel.: +603 55692322
Fax: +603 55691322

E-mail: info@lutz-jescoasia.com
Internet: www.lutz-jescoasia.com

Middle East
Lutz-Jesco Middle East FZE
P.O. Box 9614
SAIF-Free Zone Center
Sharjah
UAE

Tel.: +971 6 5572205
Fax: +971 6 5572230

E-mail: info@jescome.com
Internet: www.jescome.com

