

A dosing pump on its own is not a complete chemical feed system.

The extensive accessories programm of Lutz- Jesco converts your dosing pump into an efficient dosing system. Should you have any additional requests: We always find a solution.

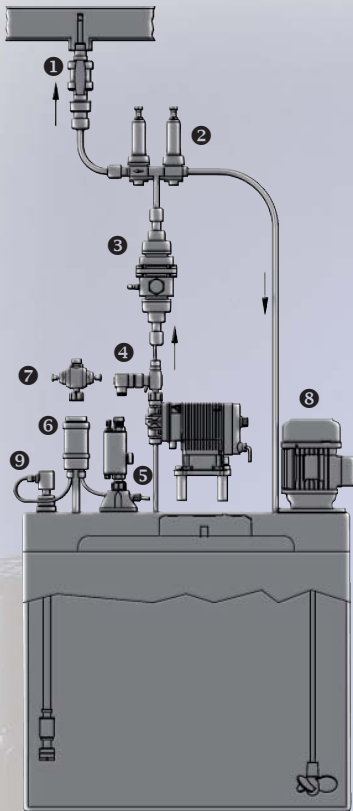

1 Injection fittings

Help to inject the chemical delivered by the dosing pumps into the system to be treated.



2 Valve assembly

Are used to increase the dosing accuracy and to protect the pump and system against excessive pressure.



3 Pulsation dampener PDS

Reduces pressure fluctuations and protects the pump and the system.



4 Electrical degassing device GAS-EX

Ensures that the pump is automatically vented in easy selectable intervals.



5 Flow sensor FLOWCON

Supervises the the flow rate and the function of the dosing pump and indicates a failure or loss of capacity of the dosing pump.



6 Priming aids

Priming becomes easy because the dosing head is supplied directly with liquid.



7 Multifunction valve PENTABLOC

Combines five functions necessary to ensure accurate and safe operation of small capacity dosing pumps: back pressure, antisiphon, safety relief, pressure relief and dosing monitoring.



8 Electric agitators JR and hand mixers

Agitators are useful armatures in order to mix or dissolve the media to be dosed homogenously. For simple mixing operated mixers are recommended.



9 Suction lines

Are available as flexible and rigid version, the length is adjustable, also equipped with integrated level controls. Special suction lines are available for transport containers.

