

TOPAX L2 / TOPAX L3

For pH and Redox Measurement



EN

02

Operation & Maintenance Instructions

Read these operation and maintenance instructions before start up!

To be held for future reference.

Table of Contents

1. General and Safety Instructions.....	4
1.1 General.....	4
1.2 Warning symbols used in this Operation & Maintenance Manual.....	4
1.3 Qualification and training of personnel	4
1.4 Important safety instructions	4
1.5 Hazards due to non-compliance with safety instructions	5
1.6 Safe operation.....	5
1.7 Safety instructions for the owner/operator	5
1.8 Safety instructions for inspection-, maintenance-, and installation work	5
1.9 Unauthorized modifications and production of spare parts.....	6
1.10 General notes of instruction!.....	6
1.11 Scope of delivery.....	6
1.12 Disposal.....	6
1.13 Overview of device functions.....	7
1.14 Technical data	8
2. Device Installation and Connection	9
2.1 Dimensions.....	10
2.2 Installation of built-in casing.....	11
2.3 Installation of wall-mounted casing.....	12
2.4 terminal connection diagram of built-in casing	13
2.5 terminal connection diagram of built-in casing	14
3. Instructions for Device Operation	15
3.1 Parameter settings	16
3.2 Menu overview.....	17
4. Password Codes and Languages	18
5. Metering Unit Settings.....	19
5.1 Calibration of pH measurement	20
5.2 Temperature compensation of pH measurement.....	21
6. Controller Unit Settings	22
6.1 ON/OFF-Controller.....	23
6.2 P-/PI-Controller as pulse-frequency controller	24
6.3 P-/PI-Controller as pulse-pause controller	25
6.4 Controller activation and deactivation.....	26

6.5 Turn-on delay	26
6.6 External controller stop	26
6.7 Manual relay control	27
6.8 Alarm	28
7. Data Readout	29
7.1 Current output.....	30
7.2 RS485 Serial interface (optional)	30
7.3 Assembly of a Data Network (TopView).....	30
8. Operation and Maintenance	32
9. Service	33
9.1 Device data.....	33
9.2 Analog inputs	33
9.3 Erase Settings (Reset).....	33
10. Error advisory	34
11. Index.....	36
12. Declaration of conformity.....	39
13. Revision.....	40
14. Warranty Application.....	41

1. General and Safety Instructions

1.1 General

This Operation & Maintenance Manual contains basic information to be noted during installation, operation and maintenance. It is therefore essential that the contractor read the manual before installing and commissioning the pump/system as well as by the relevant operating personnel/owner of the pump/system. It must remain accessible at the dosing pump/system for reference at all times.

In addition to the general safety instructions under this main heading of Safety, the special safety precautions outlined another section must also be observed.

1.2 Warning symbols used in this Operation & Maintenance Manual

This Operation & Maintenance Manual contains vital information, which may endanger people, the environment and the dosing pump/system if disregarded. These statements are identified by the following symbols:



DANGER! Refers to an imminent danger. Non-compliance can lead to death or serious injury.

WARNING! Refers to a potentially hazardous situation. Non-compliance can lead to death or serious injury.



CAUTION! Refers to a potentially hazardous situation. Non-compliance can lead to minor injury or property damage.

NOTICE! or **INFORMATION!** Appear in conjunction with safety instructions, which may endanger the pump/system and its operation if disregarded.

IMPORTANT! Draws attention to supplementary information to make the work easier and ensure trouble free operation.

1.3 Qualification and training of personnel

The personnel employed for installation, operation, inspection and maintenance work must be qualified to do so. The areas of responsibility, competence and supervision of the personnel must be precisely defined by the owner. Personnel who do not have the required knowledge must be duly trained and instructed. If necessary, this training can also be provided by the manufacturer/supplier on behalf of the dosing pump's owner. In addition, the owner of the system must ensure that the relevant personnel are fully familiar with and have understood the contents of this Operation & Maintenance Manual.

1.4 Important safety instructions

When installing and using this electrical equipment, basic safety precautions should always be followed, including the following:

1.) Read and follow all instructions!

2.) WARNING! To reduce risk of injury, do not permit children to use this product unless they are closely supervised at all times.



WARNING!

3.) WARNING! Risk of electric shock. Connect only to a grounding type receptacle protected by a ground-fault circuit-interrupter (GFCI). Contact a qualified electrician if you cannot verify that the receptacle is protected by a GFCI.



WARNING!

4.) Do not bury the cord. Locate the cord to minimize abuse from lawn mowers, hedge trimmers, and other equipment.



WARNING!

5.) WARNING! To reduce the risk of electric shock, replace damaged cord immediately.



WARNING!

6.) WARNING! To reduce the risk of electric shock, do not use an extension cord to connect the unit to the electricity supply; provide a properly located outlet.

7.) Save these instructions!

1.5 Hazards due to non-compliance with safety instructions

Failure to comply with safety instructions may endanger not only people, but also the environment and the dosing pump/system. Non-compliance with the safety instructions can lead to the loss of all entitlement to damages.

The following hazard in particular may arise:

- Danger to people due to electrical, mechanical and chemical effects.
- Failure of system functions.
- Danger to the environment due to leakage of hazardous substances.

1.6 Safe operation

The safety instructions in this Operation & Maintenance Manual must be observed.

The owner is responsible for ensuring the compliance with local safety regulations.

1.7 Safety instructions for the owner/operator

Leakages (e.g. due to ruptures in the lining) of hazardous substances (e.g. toxic or abrasive) must be discharged in such a way as to exclude all danger to people and the environment. Statutory regulations must be observed.

Danger due to electric current must be excluded (for further details, refer to the German VDE standards as well as local regulations or chapter 1.4).

1.8 Safety instructions for inspection-, maintenance-, and installation work

The owner must ensure that all inspection, maintenance and installation work is undertaken by authorized and duly qualified personnel who have also studied this Operation & Maintenance Manual.

The dosing pump must always come to a complete stop before starting any work on the pump. The procedure specified in this Operation & Maintenance Manual for shutting down the Dosing/pump/system must be observed without fail.

Dosing pumps or systems in contact with potentially harmful media must be decontaminated.

All safety mechanisms and guards must be refitted and reactivated as the work is completed.

1.9 Unauthorized modifications and production of spare parts

The device may only be modified or converted in consultation with the manufacturer. Genuine spare parts and accessories authorized by the manufacturer ensure greater safety. The use of other parts can void the liability for the subsequent consequences.

1.10 General notes of instruction!

Measuring cables must not be laid parallel or close to power supply or high-voltage current lines. Interferences would mutilate the measurement. At close distances, power supply and measuring lines may only cross at a 90° angle.

The admissible length of the measuring cables must be adhered to with regard to the sensor used. It is of decisive importance whether high-impedance (e.g. pH value) or low-impedance (e.g. free chlorine sensor) measurements are carried out. In the case high-impedance measurements, make sure that the (plug) connections are clean and dry (plug) and the lines do not become brittle due to sharp buckling. The screened cables normally used for such measuring lines must be handled according to the prescribed quality. Screening may only be connected to ground at one end of the cable (preferably at the controller).

Interface lines must be twisted and screened (see recommended cables).



IMPORTANT!

IMPORTANT!

If possible, a continuous cable from sensor to measuring input should be used. An extension of the cable by plugs or terminal socket increases the risk of disturbances due to contamination, humidity or excessive transition resistances.

1.11 Scope of delivery



IMPORTANT!

IMPORTANT!

Please unpack the dosing pump and ordered accessories with great care in order not to miss any small parts. Immediately compare the scope of delivery with the delivery note. The cause of any discrepancies must be determined.

1.12 Disposal

Should the device need to be permanently taken out of operation, please bear in mind that it contains electrolytic capacitors and must therefore be disposed of accordingly.

1.13 Overview of device functions

Metering Unit		
Metering range	TOPAX L2 (pH)	TOPAX L3 (Redox)
	0.00 - 14.00 pH -30.0 - +140.0 °C	-1500 - +1500 mV -30.0 - +140.0 °C
Displays	Measurement values with units Temperature with units Status signal sensor, calibration, controller & alarm	
Temperature compensation	manual or automatic with Pt100	
Calibration	Automatic detection of calibration-solution in any order	
Controller Unit		
Switch points	2 switch points with programmable effective direction	
Controller variants	IN/OUT-Controller, with optional hysteresis P-Controller as pulse-pause, pulse-frequency or continuous output controller PI-Controller as pulse-pause, pulse-frequency or continuous output controller	
Hysteresis	Freely adjustable over the metering range	
P-Range X_p	Freely adjustable over the metering range	
Integral time T_N	0 – 2000 sec.	
Minimum pulse	0.1 – 9.9 sec.	
Puls+pause-time	02 – 99 sec.	
Pulse frequency	100 – 7200 pulses/h	
Turn-on delay	0 – 200 sec.	
Alarm function	min. and max. threshold values und delay time	
Connections		
Relays	3 potential free contacts (2x controller, 1x alarm) 6 A, 250 V, max. 550 VA	
Analog output	0/4-20 mA electrically isolated max. load 500 Ohm	
Analog inputs	1 Measurement input for pH 1 Measurement input for Pt100	1 Measurement input for Redox 1 Measurement input for Pt100
Digital input	water deficiency safety	
Digitale Interfaces (Optional)	RS485, Baud rate 9600, dataformat 8Bit, 1start and 1stop bit, no even parity	

1.14 Technical data

Feature	Built-in casing	Wall-mounted casing
Installation site	in control cabinet	on panel or wall
Dimensions	96 x 96 x 127 mm (W x H x D)	165 x 160 x 80 mm (W x H x D)
Weight	0.8 kg	1.0 kg
Connections	Plug terminals for wiring up to max. 1.5 mm ²	spring clamps for wiring up to max. 1.5 mm ²
Protection rating	front IP54, with front door IP55	IP65
Supply voltage	230 V +6/-10%, 50/60 Hz alternating 110 V 50/60 Hz or 24 V 50/60 Hz	
Internal safety	none	230 V: 63 mA delayed 110 V: 125 mA delayed 24 V: 800 mA semi-delayed
Performance input	10 VA	
Displays	2-row LCD display, 2x16 characters, backlit, display of measurement values with relative units, additional temperature display, display of relay position	
Current output	0/4-20 mA, electrically isolated, max. load 500 Ohm	
Interfaces (Option)	RS485, baud rate 9600, data format 8 bit, 1 start and 1 stop bit	
Controller	ON/OFF-Controller with optional hysteresis, P- or PI-Controller as pulse-pause or pulse-frequency controller or continuous output controller, dual-direction PI-control possible, adjustable Turn-on delay, manual operation of relays, controller stop by external switch or gauge (water deficiency safety)	
Switch points	2 switch points, free set point within the measurement range	
Alarm function	with minimum and maximum limit values and time delay	
Contact load	6 A / 250 V, max. 550 VA ohmic resistive load (with RC protective circuit)	
Operating temperature	0 – +50°C	
Storage temperature	-20 – +65°C	
Atmospheric humidity	0 – 90% non-condensing	

2. Device Installation and Connection

Installation

Schematic diagrams and dimensions are provided over the next few pages.

An opening of 92x92mm is necessary for the device casing. The device is to be inserted from the front and fastened with the lock-on clips provided on delivery.

The wall mount casing can be hung up or pushed under into the mounting slots. It must then be fastened on with two screws.

CAUTION

The device assembly site should be chosen such that the device is not subject to any mechanical load or chemical exposure!



CAUTION!

Please note that the corresponding protection classes are:

Built-in casing: IP54 for the front end, with IP55 at the front door

Wall-mounted casing: IP65 (when the clamp cover is closed)

Connections

Connection diagrams are provided on the following pages.

Please be aware of the supply voltage indicated on the rating plate at all times.

CAUTION

Input, output, and control lead wires and cables must always be installed separated from one another and, above all, separated from high voltage lines!



CAUTION!

All input and output wires and cables need to be shielded. The shielding can only be applied on one side.

pH measurement is very sensitive to parasitic induction. Be sure to use a special, double-shielded cable. Please use an impedance transformer at long cables, high humidity or other parasitic inductions.

For Pt100 temperature sensor connection, be sure to use a heavy gauge cable with the lowest resistance possible.

When connecting to the relays, bear in mind that inductive loads need to be interference-suppressed. If this is not possible, the device terminal strip relay contacts need to be provided with an RC-protective circuit. With direct current voltage, the relays or contactor coil need to be interface-suppressed using a freewheeling diode.

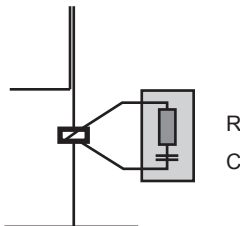

Current up to	Capacitor C	Resistance R
60 mA	10 nF 260 V	390 Ohm 2 Watt
70 mA	47 nF 260 V	22 Ohm 2 Watt
150 mA	100 nF 260 V	47 Ohm 2 Watt
1,0 A	220 nF 260 V	47 Ohm 2 Watt

2.1 Dimensions

Built-in Casing

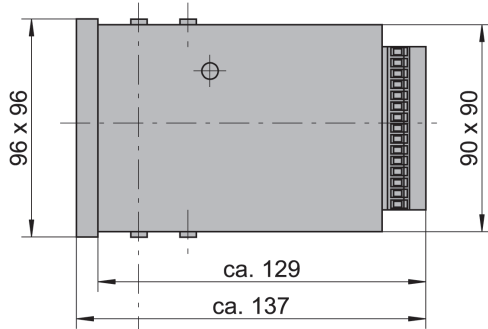

Option: Front door

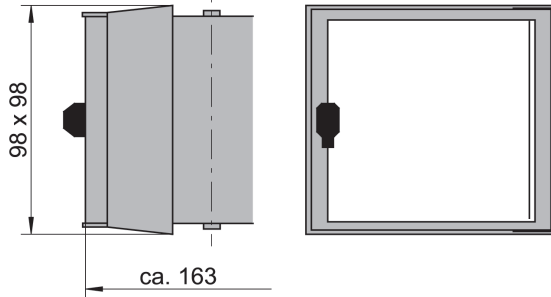

Wall-mounted Casing

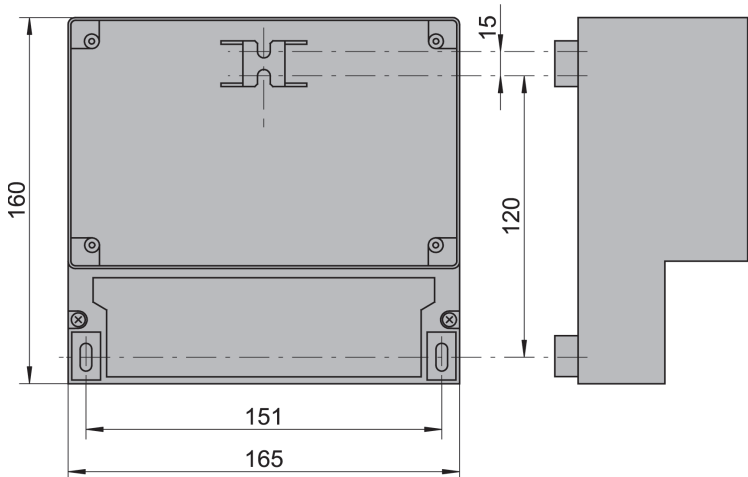

2.2 Installation of built-in casing

Prepare an opening of 92 x 92 mm.

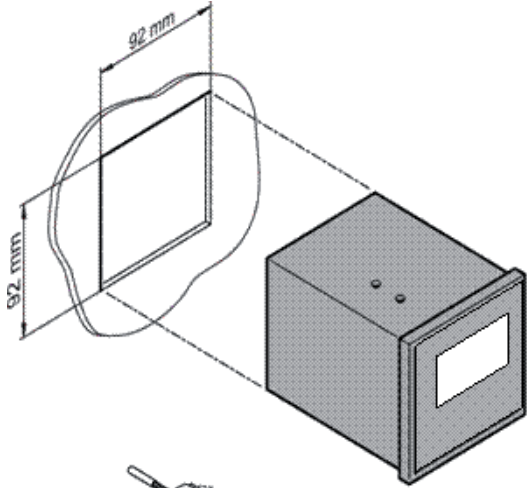

Insert the device from the fore end firmly, and fixed it on using the appropriate lock-on clips provided on delivery.

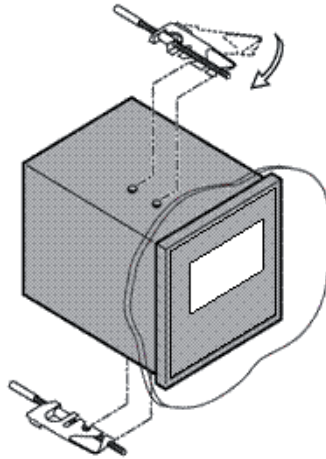

Use a screwdriver to adjust the lock-on clip screws until the device is firmly in place.

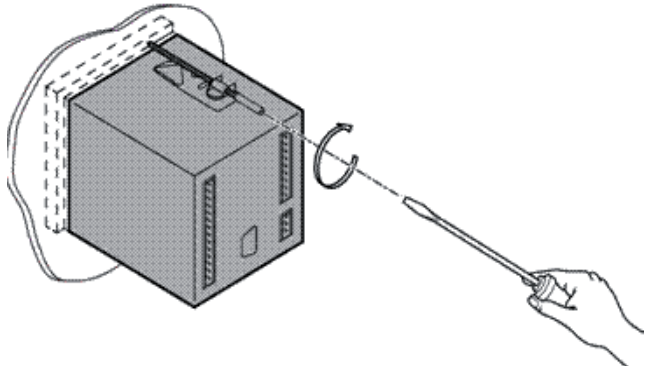

2.3 Installation of wall-mounted casing

First, remove the terminal covering.

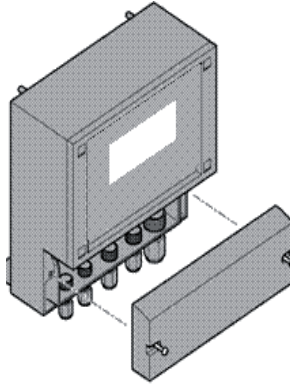

Prepare three drill holes (max. M5). Check the top hole, to ensure that the wall-mount casing can either be safely hung on or pushed under. If it is hung on, the top hole must be 120 mm above the bottom two. If it is pushed under, this distance must be 135 mm.

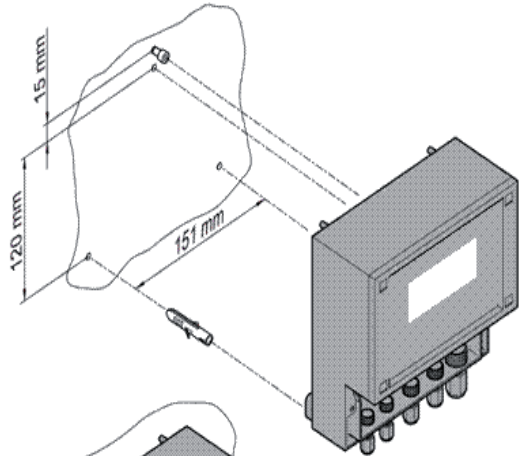

In both cases the screws must protrude outwards at least 3mm.

Hang the device onto the top screw or push it under, then fix it on via the two bottom screws. Either fit the terminal covering back on, or proceed directly with the various connections.

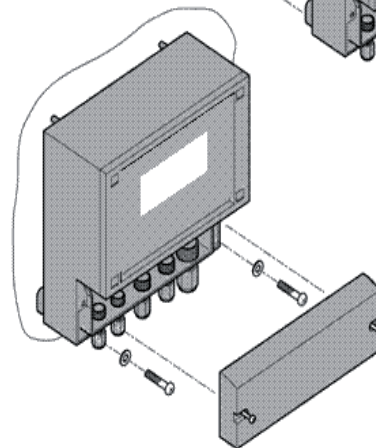

2.4 terminal connection diagram of built-in casing

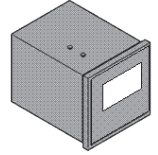

Connection	Terminals	Directions
pH electrode (TOPAX L2)	1 + 2	1 = Reference electrode = shield 2 = Measuring electrode = Internal conductor
Redox electrode (TOPAX L3)	1 + 2	1 = Measuring electrode = Internal conductor 2 = Reference electrode = shield
Temperature	5 + 6	Pt100
Analog Output	9 + 10	9 = +, 10 = -, maximum 500 Ohm load
Digital Input	11 + 12	11 = +, 12 = -, external controller stop or water deficiency
Relay 1	18 + 19	
Relay 2	20 + 21	
Relay 3	22 + 23	Alarm-Relay
Power Supply	24 + 25 + 26	Check indications on rating plate!
RS485 (Optional)	Sub-D	3 = +, 8 = -
	Sub-D 4/7	Bridge circuits = termination impedance activated

Terminal connection of sensors for measurement

TOPAX L2 (pH)

TOPAX L3 (Redox)

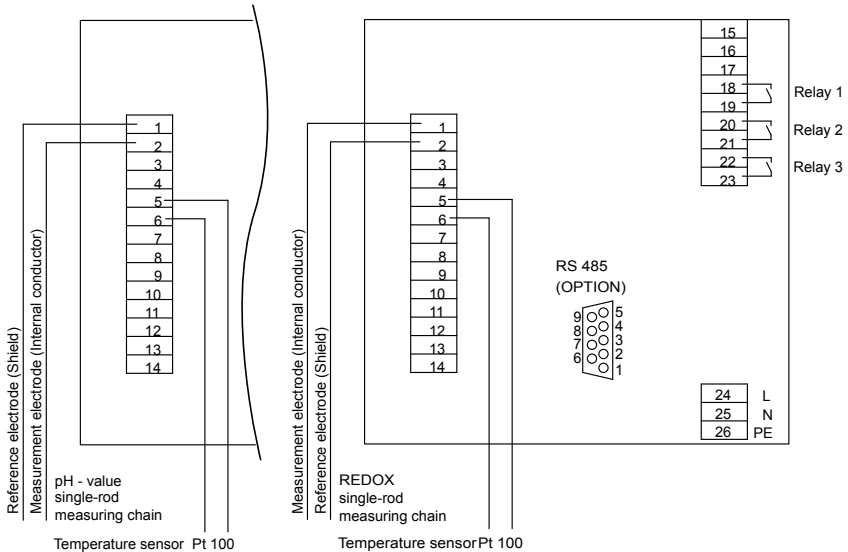

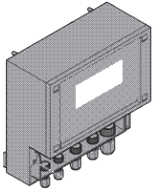

2.5 terminal connection diagram of built-in casing

Connection	Terminals	Directions
pH electrode (TOPAX L2)	1 + 2	1 = Reference electrode = shield 2 = Measuring electrode = Internal conductor
Redox electrode (TOPAX L3)	1 + 2	1 = Measuring electrode = Internal conductor 2 = Reference electrode = shield
Pt100	6 + 7	
Display-contrast	Display	Trimmer for adjustment of display contrast
Analog Output	11 + 12	11 = +, 12 = -, maximum 500 Ohm load
Relay 1	14 + 15	
Relay 2	16 + 17	
Relay 3	18 + 19	Alarm-Relay
Power supply	20 + 21 + 22	Check indications on rating plate!
RS485 (Optional)	23 + 24	23 = -, 24 = + Jumper A plugged in = termination impedance activated
Digital Input	26 + 27	26 = +, 27 = -, external controller stop or water deficiency

Terminal connection of sensors for measurement

of pH

of Redox

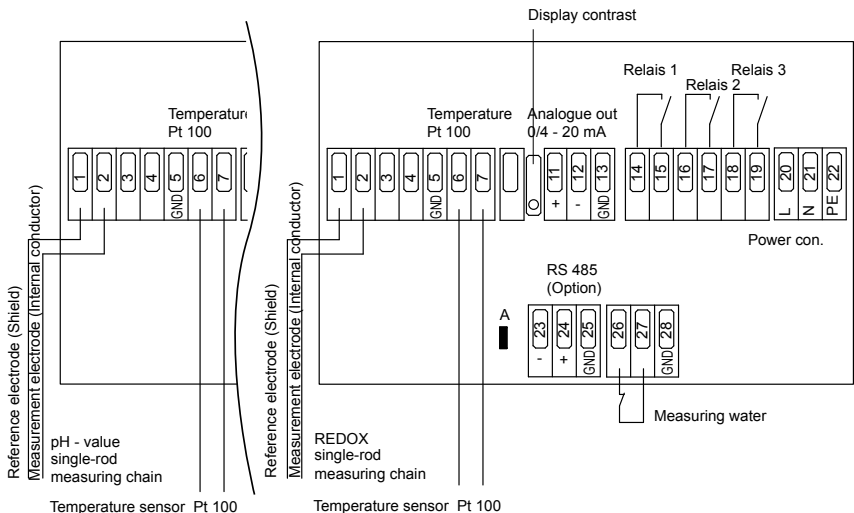

3. Instructions for Device Operation

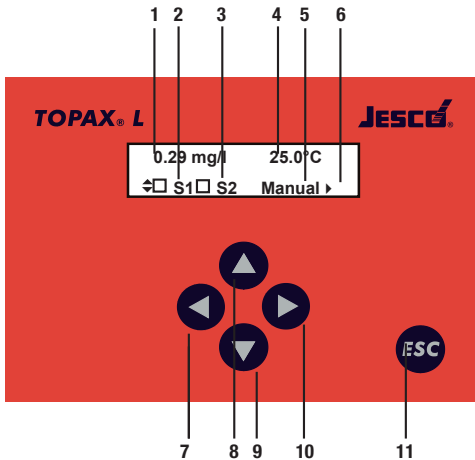

- 1 Measurement value
- 2 Relay 1 activation mode
- 3 Relay 2 activation mode
- Relais OFF
- Relais ON
- 4 Temperature
- 5 Controller operation mode
 AUTO: Controller ON
 MANUAL: Controller OFF
 (Manual relay operation)
- 6 Direction indicator
- 7 LEFT arrow key (◀)
- 8 UP arrow key (▲)
- 9 DOWN arrow key (▼)
- 10 RIGHT arrow key (▶)
- 11 „ESC“ key

Once switched on, the device will initially display the measuring value data with the operating mode of the controller (Auto/Manual) and the activation mode of relays S1 and S2.

It is possible to scroll through the menu using the operating keys:

Use key ▼ to go from the measuring value indication to the main menu.

Use key ▲ und ▼ to scroll upwards and downwards..

Use key ▶ to select a menu or a parameter.

Use key ◀ to exit a menu and to save/enter data.

To facilitate orientation, different triangles are visible on the display. They should serve as direction indicators, advising you in which directions you can scroll from your current position.

The “ESC” key will always bring you back to the measuring value indication.

3.1 Parameter settings

- | | |
|---|---|
| <p>Temp. comp.
⇌ Manual comp.</p> | 1) When a parameter is selected its current setting is displayed. |
| <p>Temp. comp.
⇌ Automat. comp.</p> | 2) Change to the next option by pressing the ▶ key. |
| <p>Temp. comp.
⇌ Manual comp.</p> | 3) After scrolling through all the options, pressing the ▶ key again will return you to the original setting displayed. |

Selection of the various options

In most cases, all that is required is a selection between the various options provided. For example, when you need to select either manual or automatic temperature compensation, simply use the ▶ key to scroll across from one option to the next, until you come back to the start point or until you reach the option required.

For these parameters, any changes are effective immediately upon selection. There is no need to enter an extra saving command for setting activation.

- | | |
|--|--|
| <p>Enter Password
^▶ 058 Code</p> | 1) Select the parameter by pressing the ▶ key. |
| <p>Enter Password
◀ 058 ⇌ Code</p> | 2) A double triangle appears behind the number and indicates that the number can now be changed using the ▲ and ▼ keys. |
| <p>Enter Password
^▶ 062 Code</p> | 3) When you have set the desired value, save the setting by pressing the ◀ key. The double triangle will disappear – the new value has been saved. |

Numeric parameter settings

Numeric parameter settings can generally only be modified when a double triangle is visible behind the number. This double triangle will first become visible when the number is selected with the ▶ key.

Change the number using the ▲ and ▼ keys. A short press of the key will increase or decrease the last digit by 1. When the key is held longer, the numeric value begins to change and will continue until the key is released.

Save your settings by pressing the ◀ key. The double triangle will disappear.



NOTE!

NOTE

If you do not wish to save a setting, press the “ESC” key instead of the ◀ key.

3.2 Menu overview

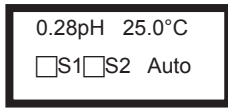

Main menu

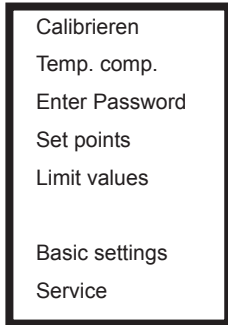

Basic settings

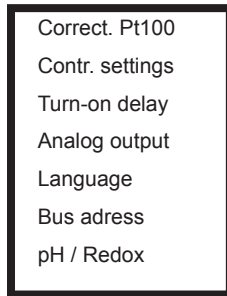

Measurement value display

The main menu is reached by pressing the ▼ key:

Calibration funktion¹⁾

Temperature compensation¹⁾

Password funktion

Controller settings - Set points, P range, I-gain range

Alarm funktion

All parameters that, in principal, only have to be set once - when putting the device into operation the first time - are found in the "Basic settings" menu.

1) pH measurement only

Main menu and basic settings

The parameters are divided into two menus. In the main menu all the functions which are used on a regular basis are listed. The basic settings menu includes those parameters which are only set once, when the device is being put into operation for the first time.

The manner in which parameters can be set and which parameters are important for your needs are described in the following pages. They are arranged according to the order of operational start-up:

- 1) Basic settings: Password codes and languages
- 2) Metering unit settings: calibration, temperature compensation and switching to redox measurement respectively
- 3) Controller setting: Selection of controller variant and corresponding parameters
- 4) Data readout settings: analog, digital and/or as alarm

4. Password Codes and Languages

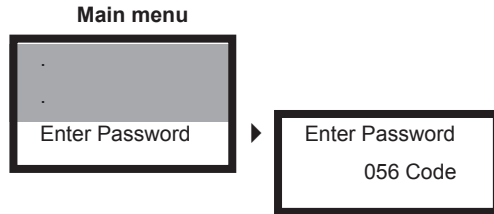

Entering password codes

Before setting functions can be accessed, the corresponding password code must be entered:

Password code 11 allows access to commonly used functions such as “calibration”, “temperature compensation” and “controller setting”.

Password code 86 allows access to all parameters and functions.

Any other codes will not enable access to any parameter or function.

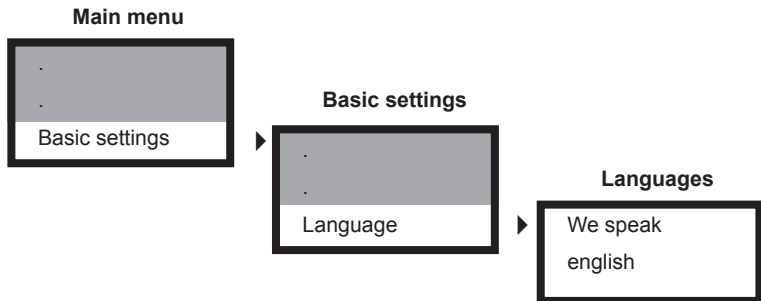

Languages

There is a selection of languages available for device communication.

Since the language settings are part of the fundamental device settings, password code 86 is necessary. If a different password code has been set, you will immediately be requested to enter the required code number.

5. Metering Unit Settings

Calibration of pH measurement and display of the slope rate and sensor zero point.

Selection of either automatic or manual temperature compensation; for manual compensation the temperature must be pre-set.

Calibration of the temperature measurement

pH measurement

pH measurement requires a calibration.

By means of calibration the electrode's characteristics are determined and stored. The procedure is a subsequent measurement of two solutions with a known pH. The pH values of the buffers used asd calibration solutions are stored in the menu basic settings.

You have to adjust the calibration data only if you want to use special calibration solutions or electrodes with a special buffer solution.

The electrode's slope is influenced by temperature. This influence can be compensated by manual or automatic compensation. Manual compensation means that the temperature is entered manually. Automatic compensation requires measuring the temperature with a Pt100.

Redox measurement

ORP measurements do not require calibration or temperature compensation. Therefor the parameters „calibration“ and „temperature compensation“ do not appear in the menu if ORP measurement has been selected.

Calibration solutions which are configured with the „calibration data“ menu will be detected automatically, in any order.

5.1 Calibration of pH measurement

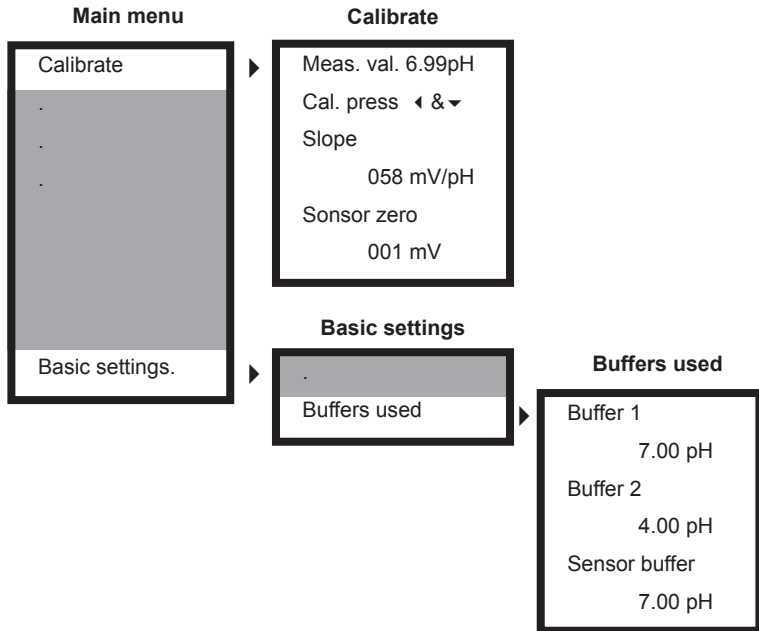

The calibration solutions stored as „buffers used“ are recognised automatically. It does not matter whether you start with buffer 1 or 2.

Calibration procedure

- 1) Switch the controller OFF and select manual temperature compensation. Enter the temperature of the calibration solutions.
- 2) Immerse the electrode in one of the calibration solutions. Wait until the measured value is stable, then calibrate by pressing keys ◀ and - while still applying pressure - additionally key ▼ . The pH of the calibration solution is now displayed as measured value.
- 3) Rinse the electrode and repeat step 2 with the second calibration solution.
- 4) Check the slope and sensor zero-point, then put the electrode back into the armature. Select automatic temperature compensation and switch ON the controller.



NOTE!

NOTE

The slope should be close to 59 mV, the zero-point close to 0 mV. The slope decreases and the zero error increases with time. When either value exceeds certain limits, the instrument displays an error message indicating that the electrode has to be replaced.

Buffers

At works the following buffers are stored:

Calibration solutions: buffer solutions pH 4 and pH 7

Inner buffer of the electrode: pH 7

If you want to use other calibration solutions, adjust the values - it does not matter if you start with the higher or the lower pH.

If you are using electrodes with a special inner buffer, adjust the pH value of the sensor buffer, since this value is used as zero for the calculation of the measured values. You will find the pH of the sensor buffer printed on the electrode.

5.2 Temperature compensation of pH measurement

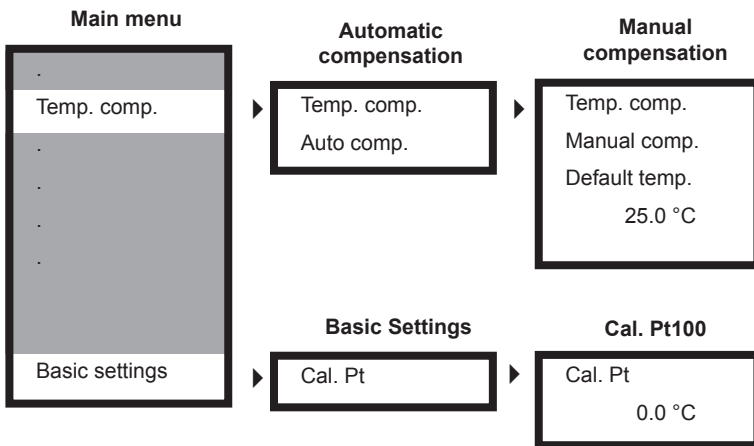

Two options are provided for temperature compensation:

- 1) Automatic compensation with temperature sensor connection

Ensure that the temperature sensor consistently records the temperature that the electrode is exposed to. When the temperature sensor and the electrodes are not in the same solution, we recommend that you opt for manual compensation.

- 2) Manual compensation

If the temperature remains sufficiently constant, it is also possible to set the temperature manually. The device then constantly compensates the measurement value based on the temperature influence of the temperature as set.

Temperature measurement calibration

If the temperature sensor is hooked up using dual-lead technology slight variations in temperature measurements may occur. The temperature measurement can thus be calibrated.

Measure the temperature once manually while putting the device into operation and correct for the temperature measurement accordingly.

6. Controller Unit Settings

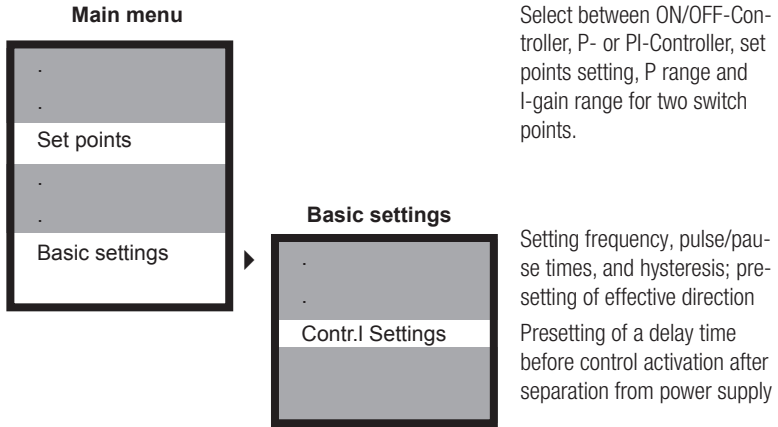

For control functioning, it is imperative that the set points and effective direction be set. This means you must determine which values you want to achieve with the metering and if the metering will increase or decrease the measurement value.

For control implementation, you can select from three controller variants:

ON/OFF-Controller

The ON/OFF controller switches ON when a switch-point threshold is exceeded and goes OFF when a threshold is under-run, or vice versa, depending on effective operating direction. Metering is therefore always carried out at 100% (ON) or 0% (OFF). A hysteresis can be preset as one of the Contr. settings.

P-Controller

The P-Controller or Proportional Controller provides for metering reduction upon approaching of the set point, proportional to control deviation. This always occurs when using the power output as control output, when using the relay either via reduction of the switching frequency (pulse-frequency Controller) or via reduction of the time span of a preset switch frame with the relay CLOSED (pulse-pause controller). Setting of the P range is required and, depending on the application, the setting of the pulse frequency, pulse + pause time and minimum pulse parameters.

PI-Controller

The PI-Controller is a P-Controller with an additional I-function. Set-up is carried out as per the P-Controller, whereby the additional setting of a Integral time, corresponding to the "I" integral gain, is also required. The "I" gain locks on later than the P-Controller and principally eliminates residual control deviation, which is always present with the P-Controller.

6.1 ON/OFF-Controller

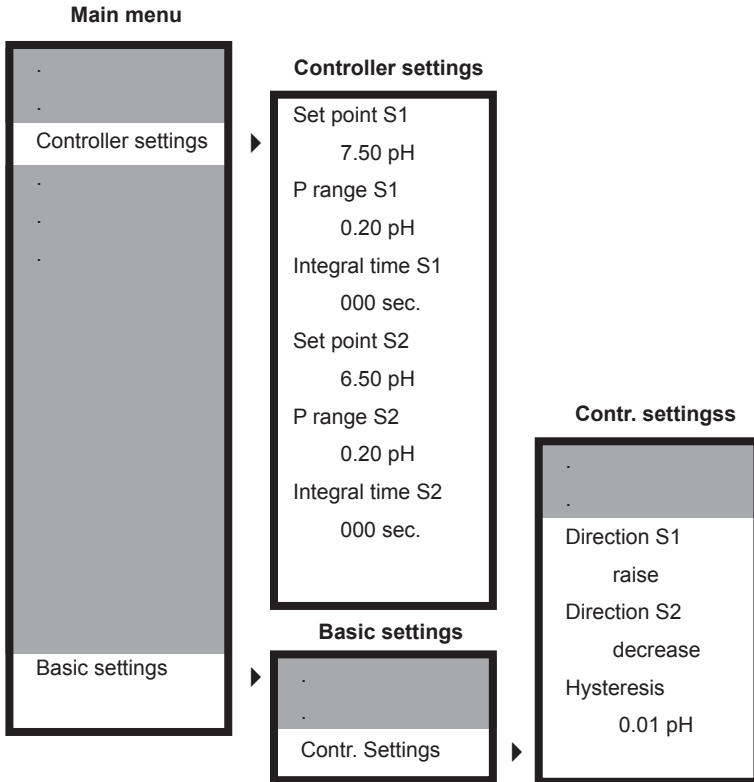

The following parameters must be set for the ON/OFF-Controller:

- 1) Set points S1 and S2
S1 corresponds to Relay 1, S2 to Relay 2.
- 2) P range and Integral time for S1 and S2
Set the P range = 0 and Integral time = 0, such that your controller functions as an ON/OFF-Controller.
- 3) Effective operating direction for S1 and S2
Set the “raise” option, if the metering increases the measurement value.
Set the “lower” option if the metering decreases the measurement value.
- 4) Optional hysteresis
The hysteresis prevents the relay from constantly switching back and forth when approaching the set point. When the hysteresis is set, the relay does not switch until the set point has been exceeded or under-run by half of the hysteresis.

6.2 P-/PI-Controller as pulse-frequency controller

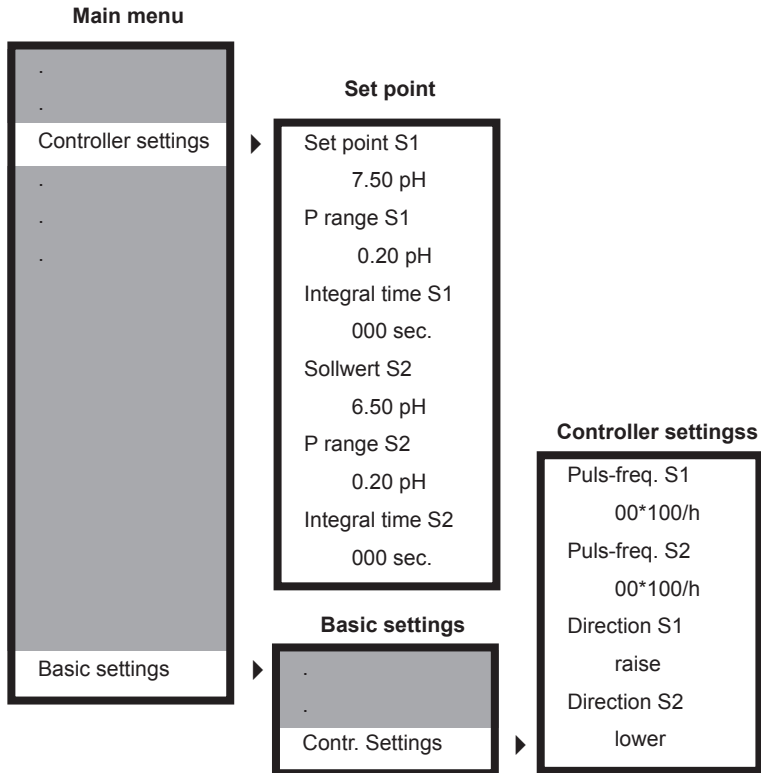

Different controller settings can be selected for S1 and S2.

The following parameters must be set for the Pulse-frequency controller:

- 1) Set points S1 and S2
S1 corresponds to Relay 1, S2 to Relay 2.
- 2) P range and Integral time for S1 and S2
Enter a P range > 0.
For a P-Controller it is necessary that Integral time = 0,
for a PI-Controller the Integral time must be > 0.
- 3) Pulse-frequency for S1 and S2
Preset the maximum pulse frequency, which would correspond to a metering of 100%.
- 4) Effective operating direction for S1 and S2
Set the "raise" option, if metering increases the measurement value.
Set the "lower" option if metering decreases the measurement value.

6.3 P-/PI-Controller as pulse-pause controller

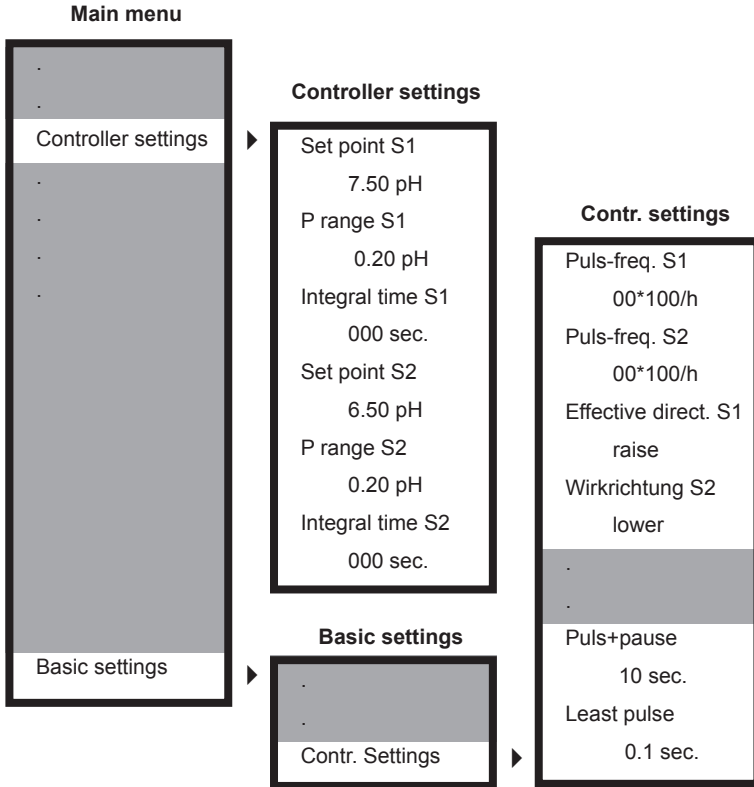

Different controller settings can be selected for S1 and S2. The pulse+pause time must be at least twice as great as the minimum pulse time. The following parameters must be set for the pulse-pause controller:

- 1) Set points S1 and S2: S1 corresponds to Relay 1, S2 to Relay 2.
- 2) P range and Integral time for S1 and S2: Enter a P range > 0. For a P-Controller it is necessary that Integral time = 0, for a PI-Controller the Integral time must be > 0.
- 3) Pulse-frequency for S1 and S2: Both frequencies must be set to 00 otherwise the controller functions as a pulse-frequency controller.
- 4) Effective operating direction for S1 and S2:
Set the “increase” option, if metering increases the measurement value.
Set the “decrease” option if metering decreases the measurement value.
- 5) Pulse+pause time: Define a time frame in which the relay is CLOSED (pulse) and OPEN (pause) proportional to the control deviation.
- 6) Minimum pulse time: Set the minimum time that the relay must be CLOSED such that the connected actuator meters out any amount at all.

6.4 Controller activation and deactivation

The controller can be activated and deactivated directly from the measurement value display by pressing the ► key. With this, operation is changed from manual (controller OFF) to automatic (controller ON) and vice versa. The current operating mode will appear on the display.



WARNING!

WARNING!

Ensure that the controller is deactivated before connecting metering pumps or other similar devices to the unit!

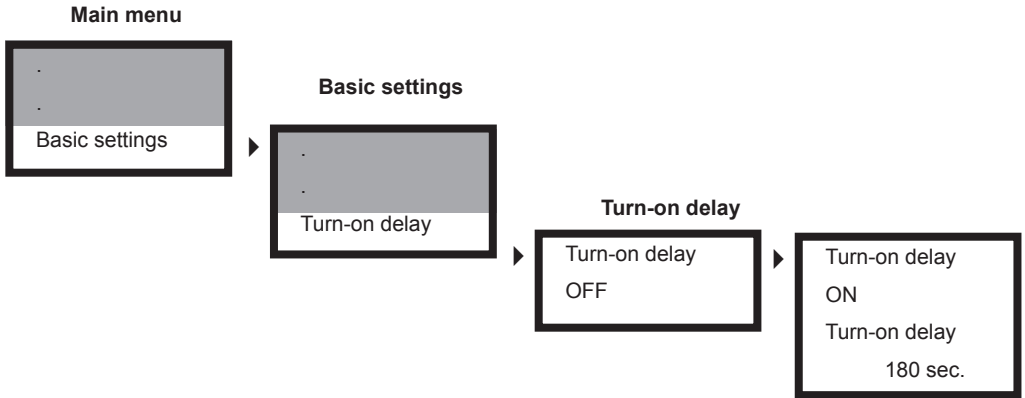

6.5 Turn-on delay

With the Turn-on delay, upon putting the device into operation the first time or on subsequent occasions or after disconnection from the main power supply, you can enter a time which must elapse before the controller becomes active. This delay time gives the measuring processes time to settle and stabilise, thereby preventing false metering incidents in the device start-up phases.

6.6 External controller stop

It is also possible to switch the device ON and OFF externally. No settings are required to do so. You must simply connect an external switch to the digital input. When the input is opened, the controller stops and the “Water Deficiency” message will come up on display.



NOTE!

NOTE!

This function can also be utilised as a water deficiency protection by connecting a float gauge.

6.7 Manual relay control

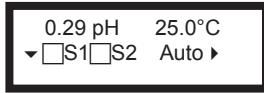

If the controller is set to automatic, change it to manual operation by pressing the > key.

Instead of "Auto", "Manual" will appear in the display.

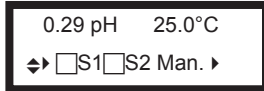

2) Change into the S1 switch mode by pressing the ^ key.

The box to the left of S1 will begin to blink.

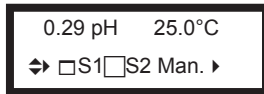

3) Switch Relay 1 ON by pressing the > key.

The box to the left of S1 will become dark.

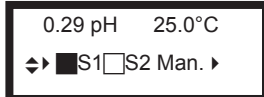

4) By again pressing the > key, the relay is switched OFF again. The box will become light again.

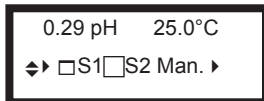

5) Change to the S2 switch mode by pressing the ^ key.

The box to the left of S2 will begin to blink.

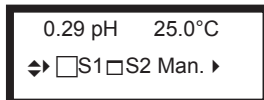

6) Switch the relay ON by pressing the > key.

The box to the left of S2 will become dark.

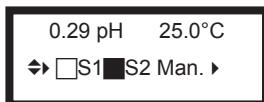

7) By again pressing the > key, the relay is switched OFF again. The box will become light again.

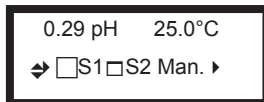

8) Exit the S2 switch mode by pressing the ^ key.

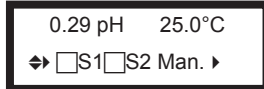

When both boxes are light and neither is blinking you have exited the switch mode.

Manual control of the relay is possibly directly from the measurement value display.

With the ▶ key, switch the controller to manual operation.

Using the ▲ key, change between manual operation <> S1 switch mode <> S2 switch mode <> manual operation.

In switch mode, the selected relay can be switched on and off using the ▶ key.

A blinking box signifies a relay in switch mode.

A dark box signifies an activated relay.

A light box signifies a deactivated relay.



WARNING!

WARNING!

Manually activated relays remain activated until they are manually switched off!

6.8 Alarm

You can set two threshold values. Threshold value 1 is an upper threshold value. If it is

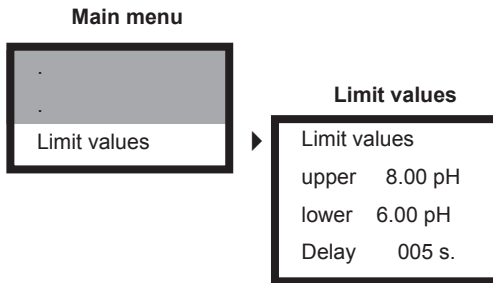

exceeded, the alarm will be activated. Threshold value 2 is a lower threshold value. If it is under-run, the alarm will be activated.

In both cases, the display will show the advisory “Threshold value exceeded”, and Relay 3 will switch. This can, in turn, activate an external sound warning such as a horn, or a warning lamp.



NOTE!

NOTE!

The alarm function is only active if the controller is switched on, with the display showing it is in AUTO mode. If the controller is switched to MANUAL, the alarm alert is cancelled and the relay will switch OFF.

Alarm delay

Depending on the type of control processes being run, threshold values can also be exceeded during standard operations. To prevent that during any such brief overshoots an alarm is set off, it is possible to set a delay time that must elapse before the alarm is activated.

In other words, the alarm will be activated only when the threshold value is either exceeded or under-run for a longer period of time than the delay time setting.

7. Data Readout

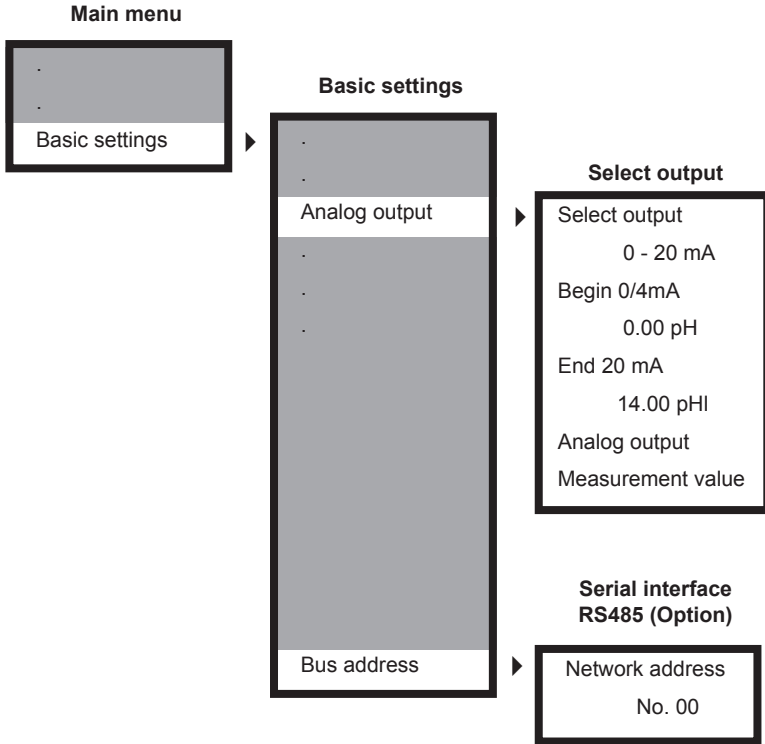

Select

- between 0-20 mA and 4-20 mA
- the measurement value at 4 mA
- the measurement value at 20 mA
- between register output and controller output

If the controller is integrated into a data network, a Network address between 1 and 15 must be entered.

CAUTION!

The network address “10” is not allowed.



CAUTION!

7.1 Current output

You can read out the measurement values as a 0/4-20 mA signal over the current output. By setting the 4-20 mA signal, resolution is indeed lost; defective cable connections are, however, immediately recognizable.

With the start value and end value parameters, you can decide which section of the measurement range you register over the current output.

As an alternative, you can also use the current output as a permanent register output and assign the actuating variable of S1 or S2. In this case, the start and end values should not be taken into account.

7.2 RS485 Serial interface (optional)

The devices can be supplied with an optional RS485 interface for data bus integration. The interface does allow for readout of all data and settings. All information for the communication is available on request.

7.3 Assembly of a Data Network (TopView).

With the (optional) RS 485 computer interface it is possible to transfer data to a PC. Furthermore multiple TOPAX L/LFs can be connected to a network. Each TOPAX L/LF (with RS 485) has to be allocated an address for this purpose.

The maximum length of data transfer amounts to 1000 m. Up to 14 TOPAX L/LFs can be connected with a PC to a network. The data line has to be attached directly to the TOPAX L/LF's RS 485 terminal:

Casing	Connection		Allocation	
wall assembly	terminal	18	+	A
		17	-	B
mounting	sub-D	3	+	A
		8	-	B

CAUTION!

Separate connection sockets or junction boxes within the data line have to be avoided. One must use a cable type "KAT.5, 2X2XAWG24/1 (Lapp cable) or better. The manufacturer is not liable for this.

Due to electromagnetic compatibility the cable's screen has to be connected on both sides before the device connections large surface area and conduct well with the protective earth. For this it has to be confirmed that no potential current loss can escape over the screen.

Today's computers are equipped with a serial computer interface RS 232 (9-pin Sub-D connector) and/or with a USB-connector. In this case an additional connector converter has to be inserted in the PC (RS 485 to RS 232 or RS 485 to USB).

120 ohm cut-off resistances.

At both ends of the network the data line has to be cut off with a resistance of 120 ohm. It is possible to put the switch for the resistance on the last TOPAX L/LF in the network

through the composition of jumpers (see chapter 2.4 and 2.5).

If the connector converters with order no. 44300101 (RS 232 to RS 485) or no. 44300102 (USB to RS 485) are attached to the PC, the cut-off resistance of the PC's sides is already activated.

Pull-up/pull-down resistance.

The data line has to be set at a fixed potential. A cut-off of the cable with Pull-up/Pull-down resistances is fundamentally necessary for the RS485-connections, in the times, in which the data sender is active, in order to exact the quiescent level on the bus system. Without this measure it is not possible to transfer data.

To activate all resistances jumpers have to be attached to the TOPAX DE (see following illustration). For this purpose the device front has to be unscrewed and flipped up.

CAUTION!

It is not at all possible to install resistances for Pull-up/Pull-down on a TOPAX L/LF. (However, the resistances for Pull-up/Pull-down can be activated on a TOPAX DE or TOPAX DX).

To guarantee the transfer of data with only TOPAX L/LF devices and/or with a TOPAX L/LF to the network end, one must install an additional bus terminal (order no. 41900001) to the PC. The Pull-up/Pull-down resistances are inserted into it.

TopView

To visualize the data read out in the network we offer the application TopView 2.0 in two versions: Standard and Mini. The programme "TopView 2.0 Standard" has the order no. 78349. The Software "TopView 2.0 Mini" is free to download from the manufacturer's website.



WARNING!



CAUTION!



NOTE!

8. Operation and Maintenance

Device maintenance

Device operation is maintenance free. No check settings are required during operation. Should you however require a verification of your device at any time, you can forward it to us. It shall be returned to you within two weeks together with a protocol test report.

Display contrast

The display contrast of the device can be adjusted in the wall-mounted casing using a potentiometer. The potentiometer is designated by “Display” in the connection diagram.

Safety protection replacement

Wall mounted devices are equipped with an internal safety protection that may have to be replaced under some circumstances. A spare safety protection is accordingly provided on issue with the device. You will find it is stored in the terminal covering. Instructions regarding safety protection are provided under the “Technical Specifications” section herein.

For safety protection replacement, it is necessary to unscrew and remove the front end of the device by carefully flipping it upwards. The safety protection is located below and on the right hand side. It is locked on with a bayonet catch. Rotate the catch leftwards, until the safety protection slips out. Exchange it with the spare safety protection and fasten it in place by turning the catch rightwards. Replace the front end of the device again and screw it on firmly.

WARNING!

Prior to opening the device, make sure that it is completely powered down!

CAUTION!

During service and maintenance operations, be careful with the connection cable located on the front of the device!

Cleaning

Please ensure that during cleaning operations, the face end of the device does not come into contact with solvents such as methanol, alcohol or methylated spirits. Take care that no water leaks into the device. We recommend cleaning the device by simply wiping it with a clean, damp cloth.

Measurement maintenance of pH or redox measurement

The metallic surface of the ORP electrode must be cleaned regularly. pH and reference electrodes change with time, so their characteristics have to be determined regularly by means of calibration.

NOTE!

During each calibration, the device tests the utility of the sensors and specifies when a sensor needs to be cleaned or replaced. For more details, please refer to the “Error Advisory” section of this manual.

9. Service

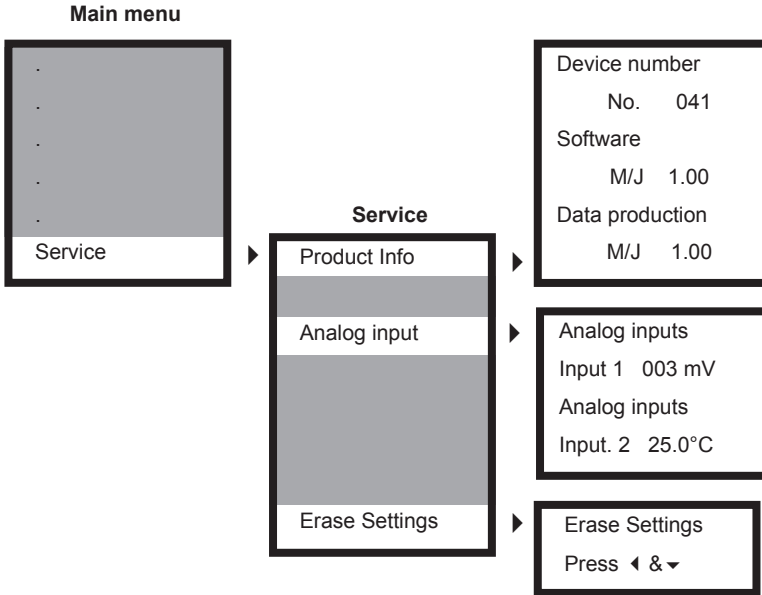

In the test functions menu you will find data that is particularly relevant for any inquiries, supplements, updates or problems.

9.1 Device data

The device data specified allow for clear device identification (of both hardware and software).

9.2 Analog inputs

This menu displays the data that the device receives from the sensors. This raw data is not influenced by compensations and calibrations and provides important information when any problems arise with measurements or device operation.

Should you have any problems with the interpretation of this data, simply inform your supplier accordingly – providing the device data – and he will be able to give some information in this regard.

9.3 Erase Settings (Reset)

This function gives you the opportunity to delete all the settings entered and to reset the device back to the original manufacturer's settings.

This process takes a few seconds. Once done, the device will return automatically to the initial measurement display page, and the controller operations will be switched off.

10. Error advisory

Error advisory	Cause	Course of action
Slope error	Calibration did not lead to an acceptable slope. This means that the slope was either higher than 65 mV/pH or lower than 50 mV/pH.	Possibly there was something wrong with the calibration procedure. Check - the connection and the cable of the sensor - the calibration solutions - the correspondence with the calibration data - the set temperature and repeat the calibration. If the message appears again, the electrode has to be replaced.
Zero-point error	Calibration lead to a zero point higher than 55 mV or lower than -55 mV.	Here as well we advise to check first the calibration solutions and the calibration data, especially the inner buffer of the electrode. If these are okay the electrode (at least the reference electrode) has to be replaced.
Error Input 1	Input 1 is not receiving a proper signal.	Check the connection and the cable of the electrode.
Error Input 2	Input 2 is not receiving a proper signal.	Automatic temperature compensation is selected although no suitable temperature sensor is connected.
Ext. controller stop	The digital input has been closed.	Open the digital input when you want to continue the dosage. If you have connected a level sensor, this message indicates lack of water.



11. Index

A

Activation delay.....	26
Alarm.....	28

C

Calibration	
Calibration data	21
Procedure	20
Connection	9
Controller	
P-Controller	22
PI-Controller.....	22
Control parameter ON/OFF-Controller.....	23
Control parameter P-/PI-Controller	24

D

Device data	33
Device functions	7
Dimensions	10
Display.....	15

E

Erase Settings	33
Error advisory	34
External controller stop.....	26

H

Hysteresis.....	23
-----------------	----

I

Inner buffer of the electrode.....	21
Installation built-in casing	11
Installation wall-mounted casing	12
Interface.....	7

K	
Keys.....	15
L	
Languages	18
M	
Menu Overview	17
Metering range	7
O	
Operation an Maintenance.....	32
P	
Password code	18
Protection rating	8
Pulse-frequency controller	24
Pulse-pause controller.....	25
R	
Redox-Messung.....	19
Relay.....	7
Manual relay control	27
RC-protective circuit	9
Reset	33
RS485	29
S	
Sensor zero-point.....	20
Service.....	33
Set point.....	22
Setting controller unit	22
Setting metering unit.....	19
Setting parameters.....	16
Slope	20
T	

Technical data	8
Temperature compensation	21
terminal connection diagram	
Built-in casing	13
wall-mounted casing	14
TopView	31
W	
Warranty	41
Z	
Zero-point	20

12. Declaration of conformity

This declaration is no assurance of characteristics in the sense of the product liability law. The safety notes in the operation & maintenance instructions must be observed.

Page 1 of 2



EG - Konformitätserklärung

Hiermit erklären wir, Lutz-Jesco GmbH
Am Bostelberg 19
D - 30900 Wedemark

dass das nachfolgend bezeichnete Produkt aufgrund seiner Konzipierung und Bauart in der von uns in Verkehr gebrachten Ausführung den einschlägigen grundlegenden Sicherheits- und Gesundheitsanforderungen und den unten aufgeführten EG-Richtlinien entspricht.
Bei einer nicht mit uns abgestimmten Änderung des Produktes verliert diese Erklärung ihre Gültigkeit.

Bezeichnung des Produktes: Mess- und Regeleinheit

Typenbezeichnung: TOPAX L

Einschlägige EG-Richtlinien: EG-Niederspannungsrichtlinie (73/23/EWG)
EG-Richtlinie Elektromagnetische Verträglichkeit
(89/336/EWG) i.d.F. 93/31/EWG

Angewandte harmonisierte: EN 55011 :1998 +A1:1999 +A2:2002 Störaussendung,
Industrieumgebung
EN 61000-6-2 :2001 Störfestigkeit, Industrieumgebung

Datum, Hersteller-Unterschrift: 19.12.2006.....i.V.....*Albus* *MMA*

Angaben zum Unterzeichner: Herr Klaus Albert, Dipl. Ing.
Leiter Technik

Die Anhänge sind Bestandteil dieser Erklärung.

Diese Erklärung bescheinigt die Übereinstimmung mit der genannten Richtlinie, beinhaltet jedoch keine Zusicherung von Eigenschaften.

Die Sicherheitshinweise der mitgelieferten Produktinformation sind zu beachten

19.04.2007



**Anhang zur EG - Konformitätserklärung
zur Niederspannungs-Richtlinie 73/23/EWG**

Produkt : **TOPAX L**

Angewendete Normen und technische Spezifikationen:

unter Berücksichtigung folgender EMV- Grundnormen:

- EN 61000-4-2: 1995 +A1:1998 +A2:2001
- EN 61000-4-3: 2002 +A1:2002
- EN 61000-4-4: 2004
- EN 61000-4-5: 1995 +A1:2001
- EN 61000-4-6: 1996 +A1:2001
- EN 61000-4-11: 2004

EN 61010-1 :2002-08 Sicherheitsbestimmungen für elektrische Mess-, Steuer-, Regel- und Laborgeräte

13. Revision

This Operating Manual is valid for the following devices:

Device	Revision
TOPAX L2	11/06
TOPAX L3	11/06

It contains all the technical information required for installation, start-up and maintenance. Should you have any questions or require further information regarding these operating instructions, please contact the manufacturer firm or its official national representative.

14. Warranty Application

Please copy and send with the device.

If the device breaks down within the period of warranty, please return it in a cleaned condition with the complete warranty application, filled out.

Sender

Company:..... Phone:..... Date:.....

Address:.....

Contact person:

Lutz-Jesco order-no.:..... Delivery date:.....

Device type:..... Serial no.:.....

Nominal capacity/nominal pressure:

Description of fault:

.....

.....

Type of fault:

1. Mechanical fault

- premature wear

- wear parts

- breakage/other damage

- damage in transit

3. Leaks

- connections

- dosing head

2. Electrical fault

- loose connections such as plug connector or cable

- operating elements (e.g.. switches/buttons)

- electronics - corrosion

4. No or inadequate suction

- defective diaphragm

- other

Service conditions of the dosing pump

Point of use / system designation:.....

Accessories used (Suction line, PDS, etc.):.....

.....

.....

Commissioning (date):.....

Duty period (approx. operating hours):.....

Please describe the specifics of the installation and provide a simple diagram with details of the material, diameter, length and levels.







Lutz-Jesco GmbH

Am Bostelberge 19
30900 Wedemark
Germany

Phone.: +49 51 30 5802-0
Fax: +49 51 30 5802-68
E-Mail: info@lutz-jesco.de
Internet: www.lutz-jesco.de

24h-Hotline: +49 51 30 580 280

Austria

Lutz-Jesco GmbH

Aredstraße 29/212
2544 Leobersdorf
Austria

Phone: +43 2256 62180
Fax: +43 2256 6218062
E-Mail: info@lutz-jesco.at
Internet: www.lutz-jesco.at

Great Britain

Lutz-Jesco (GB) Ltd.

Gateway Estate
West Midlands Freeport
Birmingham B26 3QD
Great Britain

Phone: +44 121 782 2662
Fax: +44 121 782 2680
E-Mail: info-gb@jesco.de
Internet: www.lutz-jesco.de

Netherlands

Lutz-Jesco Nederland B.V.

Nijverheidstraat 14 C
2984 AH Ridderkerk
Netherlands

Phone: +31 180 499460
Fax: +31 180 497516
E-Mail: info@lutz-jesco.nl
Internet: www.lutz-jesco.nl

Hungary

Lutz-Jesco Üzletág

Vasvári P. u. 9.
9024 Győr
Hungary

Phone: +36 96 523046
Fax: +36 96 523047
E-Mail: info-hu@jesco.de
Internet: www.lutz-jesco.hu

USA

Lutz-JESCO America Corp.

55 Bermar Park
Rochester, NY 14624
USA

Phone: +1 585 426-0990
Fax: +1 585 426-4025
E-Mail: mail@jescoamerica.com
Internet: www.jescoamerica.com

East Asia

Lutz-Jesco
East Asia Sdn Bhd

Taman Perindustrian Jaya
47200 Petaling Jaya
Malaysia

Phone: +603 78454812
Fax: +603 78458413
E-Mail: info@lutz-jescoasia.com
Internet: www.lutz-jescoasia.com

Middle East

Lutz-Jesco Middle East FZE

P.O. Box 9614
SAIF-Free Zone Center
Sharjah
UAE

Phone: +971 6 5572205
Fax: +971 6 5572230
E-Mail: info-me@jesco.de
Internet: www.jescome.com



Order-No. BA-40500L23-02-V04
Subject to technical changes
© Lutz-Jesco GmbH 05.2007
Printed in Germany