

Suction Line SDL

for barrels and containers

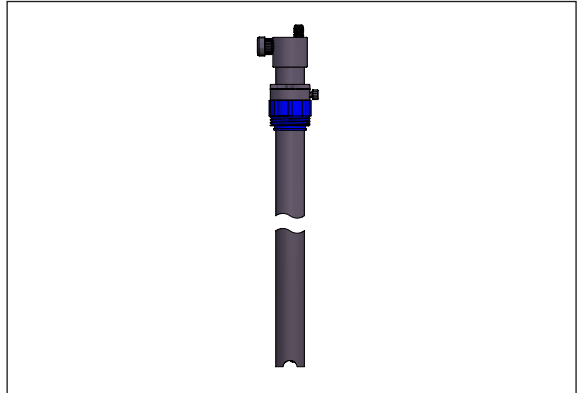

EN

02

Operating Instructions

To be retained for future reference.

1. General

With suction lines of the type SDL chemical fluids safely can be taken out of barrels and containers.

2. Dimensional drawing

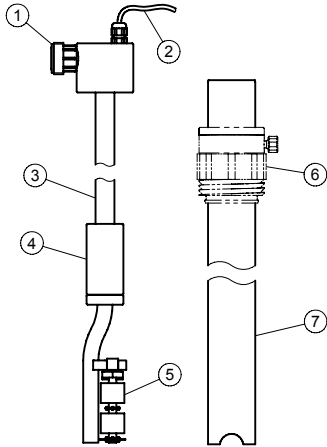

Fig. 2.1: Scheme Suction Line SDL

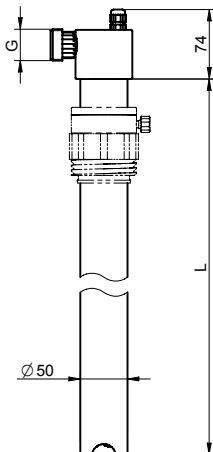

Fig. 2.2: Dimensional drawing Suction Line SDL

3. Technical data

Technical data Suction Line SDL		
①	Suction connection	Thread G1 m
②	Connection cable	5 m, 3-core, PVC
③	Suction tube	DN15
④	Non-return valve	DN15
⑤	Float switch	2 float switches for empty status signal and pre-alarm
⑥	Tank connection (optional)	Fixable threaded ring G2 or optional thread 2" Mauser
⑦	Protection pipe	Outer diameter 50 mm
	Length suction tube (L)	1000, 1200 or 1400 mm (other lengths on request)
	Glue	Tangit, optional DYTEX
	Material	PVC
	Seal	EPDM and FPM attached Use according to requirements

Tab. 3.1: Technical data Suction Line SDL

Technical data float switch	
Switching voltage	48 V
Switching current	0.5 A
Switching capacity	10 W
Protection class	IP 67
Temperature range	-25°C ... +60°C
Material	PVC

Tab. 3.2: Technical data float switch

4. Application

Before using the equipment for the first time or after changing the fluid expel the air from the unit by repeated rapid movements upwards and downwards.

5. Function

5.1 Connection

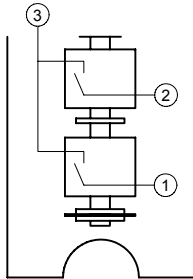

Fig. 5.1: Cable configuration: ① main alarm (white), ② pre-alarm (green) and ③ 0/Ground (brown)

5.2. Switch function of float switch

By moving the swimmer up the reedcontact is closing.

5.3. Type of contact of float switch

The contact type of the suction line SDL is „falling opened“. This means that the contact is closed with full container and switch floating high and open with empty container and switch floating low.

5.4. Reversing the contact type of the float switch

It is possible to reverse the contact type:

1. Remove retainer rings and the distance washer
2. Deinstall both float switches
3. Turn around and reinstall the float switches
4. Fix retainer rings and the distance washer

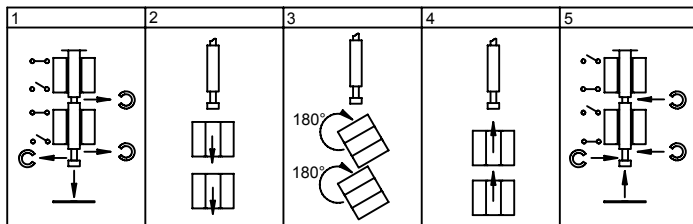

Fig. 5.2: Float switch reversing type of contact

6. Order numbers

Variants

Part No.	Type	Length (mm)	Seals	Medium-Connection	Tank connection
12200260	SDL-2	1000	FPM / EPDM	G1 m	without (optionally available)
12200269	SDL-2	1200	FPM / EPDM	G1 m	without (optionally available)
12200270	SDL-2	1400	FPM / EPDM	G1 m	without (optionally available)

Note:

All suction lines are delivered with seals in FPM and EPDM material. The customer is responsible for selecting the material according to his requirements.

Accessories

Medium connections for thread G1 m		
Part No.	Type	Size
31095	Stick-on connector	for tube d16
25626	Stick-on connector	for tube d20
24357	Hose liner connection	for hose d12
24941	Hose liner connection	for hose d16

Tank connections			
Part No.	Type	Size	Notes
38548	Barrel connection	G2 m	- This connection allows for a stepless submer- sion depth of the suction line
38549	Barrel connection	Mauser 2" external	- This connection includes article no. 38548 - This connection allows for a stepless submer- sion depth of the suction line

7. Declaration of no objection

When sending in for repair, please copy this form, fill in and send along with each device!

Declaration of no objection

Please fill out a separate form for each appliance!

We forward the following device for repairs:

Device and device type:

Part-no.:

Order No.: Date of delivery:.....

Reason for repair:

.....

Dosing medium

Description: Irritating: Yes No

Properties: Corrosive: Yes No

We hereby certify, that the product has been cleaned thoroughly inside and outside before returning, that it is free from hazardous material (i.e. chemical, biological, toxic, flammable, and radioactive material) and that the lubricant has been drained.

If the manufacturer finds it necessary to carry out further cleaning work, we accept the charge will be made to us.

We assure that the aforementioned information is correct and complete and that the unit is dispatched according to the legal requirements.

Company / address: Phone:

..... Fax:.....

..... Email:

Customer No.:

Contact person:

.....
Date

.....
Signature

8. Warranty claim

Please copy and enclose with the unit.

If the device fails during the warranty period, please clean it and return, accompanied by the completed warranty claim form.

Warranty claim

Please copy and send it back with the unit!

If the device breaks down within the period of warranty, please return it in a cleaned condition with the complete warranty claim.

Sender

Company: Phone.: Date:

Address:

Contact person:

Manufacturer order no.: Date of delivery:

Device type: Serial number:

Nominal capacity / nominal pressure:

Description of fault:

.....
.....
.....
.....
.....
.....

Service conditions of the device

Point of use / system designation:

.....
.....

Accessories used (suction line etc.):

.....
.....
.....

Commissioning (date):

Duty period (approx. operating hours):

Please describe the specific installation and enclose a simple drawing or picture of the chemical feed system, showing materials of construction, diameters, lengths and heights of suction and discharge lines.

