

Keep the operating instructions of the metering pump and the accessories readily accessible.

List of contents

1. Technical data
2. Scope of delivery
3. Drive system
4. Installation
5. Electrical connection
6. Safety instructions
7. Startup
8. Maintenance
9. Troubleshooting

2. Scope of delivery

Be careful when unpacking the metering pump and order-related accessories in order not to miss small parts. Compare the scope of delivery to the delivery note. If there are any discrepancies, try to find out the reason.

Because of the relatively high weight of the pump (150...200 kg) appropriate lifting and transportation fittings are required, e.g. ropes with a corresponding load strength have to be fastened to the pump drive and metering head suspension.

1. Technical data

Memdos GMR		2000	3000	4000
Pressure	bar	4	3	2
Flow rate	ml/str	460	690	920
Stepless control drive	Flow rate	l/h	310...2000	460...3000
	Stroke frequency	min ⁻¹	11...72	11...72
Three-phase or DC motor drive at 2850 min ⁻¹	Flow rate	l/h	1600	2400
	Stroke frequency	min ⁻¹	58	58
Power input	kW	2.2	2.2	2.2
Diaphragm diameter	m m	212	252	252
Stroke length	m m	23	26	32
Suction head	mbar	120	120	120
Max. supply pressure (Σ static + dynamic)	mbar	500	500	500
Max. temperature	°C	40	40	40
Weight	Plastic metering head	kg	145	165
	Stainl. steel meter. head	kg	155	195

3. Drive system

The metering pump Memdos GMR is a double-diaphragm pump with an excellent metering accuracy which is independent of pressure fluctuations in the system to a great extent. In order to scoop out the quality of the Memdos GMR, the glycerine must be filled very carefully into the hydraulic system.

As driving unit a direct drive with a flanged three-phase or DC motor is available as well as a belt drive with adjustable speed. The belt drive version is dealt with in a separate section of paragraph 8 "Maintenance" of this manual.

The pump output is adjusted by changing the speed. In both versions the stroke is produced by means of a fixed eccentric. A connecting rod actuates the working diaphragm. The front working diaphragm is activated by means of a hydraulic coupling and displaces the medium in the metering head during the upward stroke. During the subsequent suction stroke fresh medium is primed into the metering head resulting from the backward motion of the diaphragms.

The mechanical structure of the Memdos GMR is shown in the following drawing.

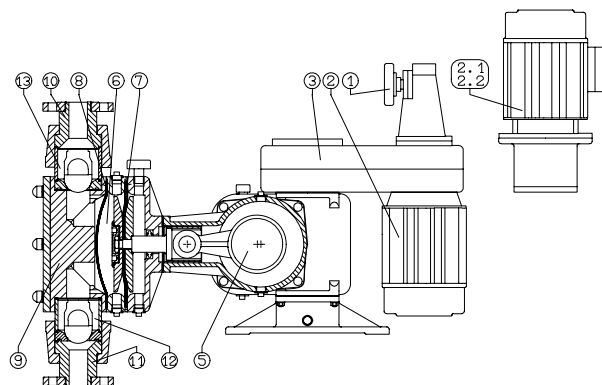

Legend

- 1 Handwheel for speed adjustment
- 2.1 DC motor
- 2.2 Three-phase motor
- 3 Belt gear
- 5 Eccentric
- 6 Glycerine filling
- 7 Rear diaphragm
- 8 Front diaphragm
- 9 Metering head
- 10 Discharge connection
- 11 Suction connection
- 12 Suction valve
- 13 Discharge valve

4. Installation

For the selection of the appropriate metering pump when planning a plant as well as for its installation and operation the local regulations in force must be observed. This applies to the selection of the appropriate pump materials, the handling of chemicals and the electrical installation. Just as well the technical data of the above table has to be considered and the design of the plant has to be effected correspondingly (e.g. pressure loss in lines depending on nominal diameter and length).

Both, the designer and the operating company are responsible to make sure that the whole plant including the metering pump integrated are constructed so that neither plant equipment nor buildings are seriously damaged in the case of chemical leakage resulting from breakdown of wear parts (e.g. diaphragm rupture) or burst tubings. In the case of a high-risk potential the plant has to be designed so that no disproportionate damage occurs even if the metering pump fails. Therefore we recommend installing leakage probes and containment tanks.

Metering pumps are produced according to the highest quality standards and have a long service life. Nevertheless some parts are subject to wear (e.g. diaphragms, valve seats, valve balls). Therefore regular visual checks are required to ensure a long operating life. Operating and maintenance personnel must be able to access the pump easily. Periodic maintenance protects the metering pump against shutdowns.

To increase the metering accuracy and reliability, we recommend using additional fittings. These include backpressure valves, relief valves, leakage probes, chemical low level indicators as shown in the installation example overleaf.

Always use appropriate tools for the installation of plastic connecting parts. In order to avoid damage, never apply excessive force. Plastic parts (especially PVC parts) can be screwed and unscrewed more easily if the thread is lubricated with vaseline or silicone grease before.

Note: For this purpose, the compatibility with the chemical to be metered must be checked.

Ambient temperatures exceeding 40°C are not permitted. Radiant heat of the equipment and heat exchangers must be kept in limits allowing the pump to sufficiently dissipate its own heat. Exposure to direct sunlight must be avoided. If the pump is installed outside provide an enclosure to protect it against weather. Also make sure that the louvers of the control gear are protected against humidity and that, nevertheless, there is enough space above the gear for an adequate ventilation.

Mount the pump so that the suction and discharge valve are in vertical position. To ensure that the pump stands firm, fasten it with screws on an appropriate foundation.

The system piping must not exert any force on the connections and valves of the metering pump. In order to avoid incorrect metering after the process is finished provide an electric and hydraulic interlocking system.

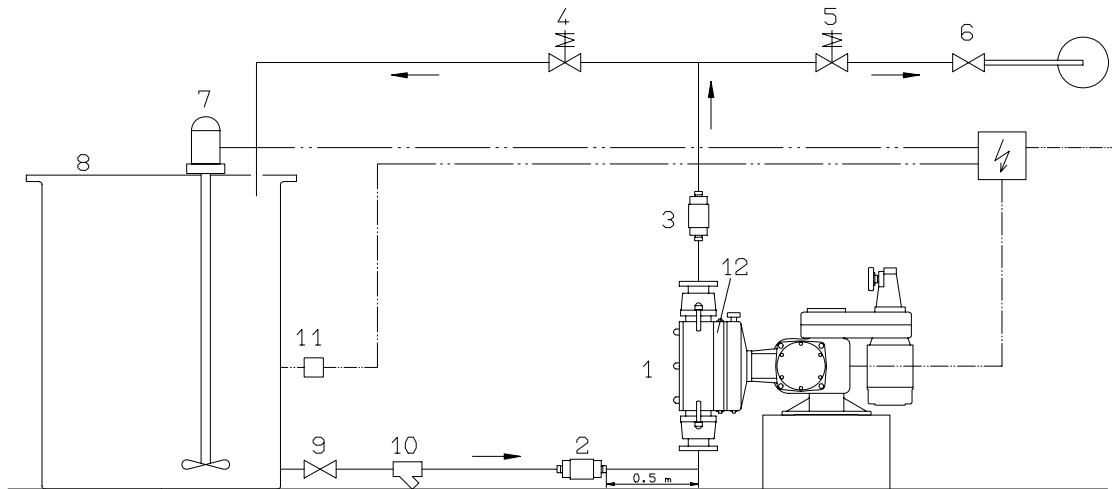
Installation example

Legend

- | | | | |
|---------------------------------------|------------|---|------------|
| 1. Metering pump GMR | MB 1 06 01 | 8. PE tank | MB 1 20 01 |
| 2. Pulsation damper f. suction line | MB 1 27 01 | 9. Connection valve/ball valve | |
| 3. Pulsation damper f. discharge line | MB 1 27 01 | 10. Strainer | MB 1 22 02 |
| 4. Relief valve | MB 1 25 01 | 11. Dry operation protection | MB 4 10 00 |
| 5. Backpressure valve | MB 1 25 01 | 12. Diaphragm rupture sensor part no. 41028906 | |
| 6. Injection nozzle | MB 1 23 01 | The fittings shown in the example can be used if necessary. | |
| 7. Electric agitator | MB 1 36 04 | | |

5. Electrical connection of pump

- The electric connection of the pump must be made according to the local regulations and may only be carried out by specialist staff.
- Cable type and cable cross section of the delivery line must be selected according to the motor specifications.
- The cable passage to the motor terminal box must be carried out professionally. We recommend gland screw connections with tensile relief.
- The protection class required must be ensured by carrying out the electrical connections professionally.

Electrical connection data

Pump size Drive type	Voltage [Volt]	Power [kW]	Current [A]
... GMR 4000 Direct drive	400/230 50Hz	2.2	approx. 4.9/8.4
... GMR 4000 Direct drive	400/230 50Hz	3.0	approx. 6.4/11.0
... GMR 4000 Belt drive	400/230 50Hz	2.2	approx. 5.2/8.9

Connection diagram of the drive motor

- Three-phase current supply

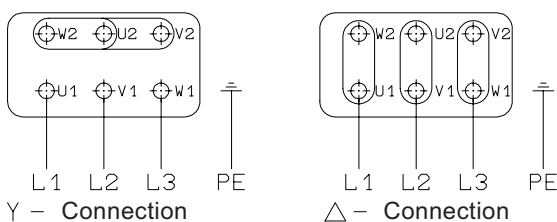

- Special versions
For other electrical versions, please refer to the corresponding separate circuit diagram.

- Electric actuating drive ATE
For the corresponding technical data and wiring diagrams, please see page 8, section 8.5 of these instructions.

6. Safety instructions

- ⇒ When working on metering equipment, make sure that the local accident prevention rules are observed (e.g. that the personal protective clothing is worn).
- ⇒ Before starting to work on the metering pump or plant make sure that the mains cable is disconnected and secure it against reconnection. Before reconnecting the mains cable, the metering lines have to be connected first to prevent the chemical which might possibly be in the metering head from spurting.
- ⇒ The metering head as well as plant connections and lines may be under pressure. Therefore you should be aware that working on metering plants requires special safety precautions and may only be carried out by trained specialist staff.
- ⇒ Before startup, make sure that all screw connections are screwed on correctly, check them for tightness and, if necessary, retighten them using the appropriate tool. The metering head screws have to be tightened and checked as shown in the figure below.
- ⇒ In the case of the Memdos GMR the separation chamber filled with glycerine may also be under pressure. Therefore the plugs and a leakage probe possibly mounted may only be removed in a pressureless state.
Note: Piping on the discharge side also has to be relieved or disconnected!
- ⇒ When changing the chemical, check the resistance to chemicals of the pump and plant component materials. If there is a risk of a chemical reaction between the different media, make sure that the units are first cleaned and flushed thoroughly.
- ⇒ To operate the pump, mount the fan shell in order to ensure adequate cooling of the motor.
- ⇒ Also make sure that the louvers of the control gear are protected against humidity and that, nevertheless, there is enough space above the gear for an adequate ventilation.

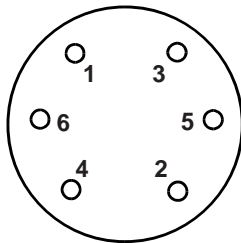

Please tighten up
at 35 Nm!

- ⇒ If there are any connections at the metering head which were unscrewed during operation for venting or other reasons, make sure that leaking chemical is removed professionally. This is absolutely necessary in order to avoid any health risks and corrosion of the metering pump. Leaking chemical may also result in destruction of the diaphragm at its clamping points.

7. Startup

1. Before starting the metering pump all working steps described in the section "Installation" have to be carried out and the safety instructions have to be observed.
2. The metering pump is switched on by a control unit installed externally.
3. The manual or electric capacity adjustment must be set to maximum stroke to improve priming. During first priming no backpressure should be applied. For this purpose we recommend to install a relief valve on the discharge side.
4. A previously mounted priming aid must be filled with chemical first. If the pump is not priming unscrew the discharge valve and fill water or chemical (if not dangerous) into the metering head. Remount valve and start priming.
5. If correct delivery is reached, set the required output by means of the adjusting button or the remote control unit. In order to obtain an approximation for the output value, please refer to output diagrams in MB 1 06 01 or to the values indicated on the type plates. Depending on the installation and the chemical used, these values may differ from those indicated and must first be tested under operating conditions.
6. The manufacturer is not responsible for damages resulting from over- or undermetering because of faulty pump settings or because of incorrect and insufficient installation of peripheral fittings.

8. Maintenance

8.1 Lubrication

The diaphragm metering pump Memdos GMR requires little maintenance. The gear of the pump is lubricated with Hypoid gear oil, viscosity class SAE 85W-90 according to DIN 51512. In the following table some of the common gear oil types are listed. The first filling has to be renewed after approx. 500 operating hours. Further oil changes should be carried out every 5,000 operating hours. The filling capacity amounts to approx. 4.5 l for the single gear and approx. 5.5 l for the duplex. The actually required quantity of gear oil can be determined by means of an oil gauge glass. Switch off the pump and fill in the oil until the glass is half-full.

The following oil types may be used as gear oil for Hypoid gear oil GL 5 according to MIL-L-2105B:

Make	Designation
Aral	Gear oil Hyp
BP	Multi-purpose gear oil EP
Esso	Gear oil GX-D
Fanal	Gear oil HD Hypoid
Mobil	Mobilube HD-A
Texaco	Multi-Gear Lubricant EP

8.2 Replacing the diaphragm

In the case of a diaphragm rupture, proceed as follows:

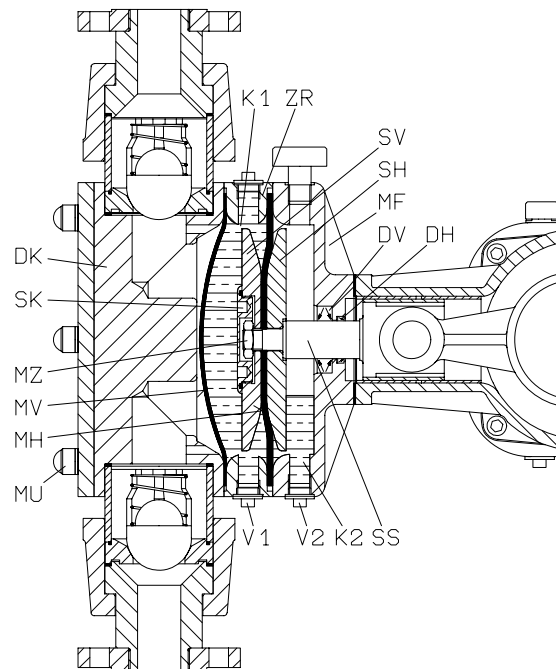

1. Drain off the chemical contained in the metering lines so that they are pressureless. In doing so, please observe the a.m. safety instructions. Dismount the connection lines and the valves and drain off the medium in the metering head.
2. Unscrew the locking screws (V1) and (V2) at the bottom side of the metering head for draining off the glycerine from the glycerine chambers (K1) and (K2). If the glycerine did not mix up with the metering medium it may be used again. However, new glycerine should be filled in preferably.

- The metering head (DK) and the glycerine chamber (K1) are screwed together with stud bolts. Unscrew the nut (MU) at the metering head first and detach then the metering head (DK), the front diaphragm (MV) and the spacer ring (ZR).

Note: The metering head is relatively heavy and must therefore be handled with special care.

- The rear diaphragm (MH) is held in between two supporting plates (SV) and (SH). For dismantling it, you first have to unscrew the protection cap (SK) and the central hexagon nut (MZ). Now you can take off successively the front supporting plate (SV), the diaphragm (MH) and the rear supporting plate (SH) from the slide rod (SS).
- Before installing the new diaphragm, the chemical and possible impurities have to be removed. Pay special attention to the sealing separating the slide rod (SS) from the gear. If the packing rings (DV) and (DH) are torn, replace them after dismantling the diaphragm flange (MF). A double-acting packing ring (DV) on the metering head side becomes visible after removing the diaphragm supporting plates (SV) and (SH). Models produced after construction year 05.96 are provided with an additional packing ring (DH) on the gear side which is accessible after removing the diaphragm flange (MF) from the gear. Watch that the lip seal is directed towards the gear. Slide the whole diaphragm flange (MF) including the replaced sealing rings (DV) and (DH) over the slide rod (SS) by using a mounting bush, adjust and screw them together on the centering of the gear.
- For mounting the new diaphragm (MH) and the supporting plates (SV) and (SH) make sure that the sliding rod (SS) is in center position. In order to reach this position, turn the motor further on at the fan wheel. Make sure that the cutouts at the diaphragm circumference match to the stud bolts.
- Now slip on successively the spacer ring (ZR), the front diaphragm (MV) and the metering head (DK) to the stud bolts. Make sure that valve cutouts of the metering head are directed vertically.

- Tighten the metering head by screwing on the nuts as shown below.

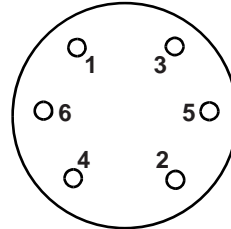

Please tighten up at 35 Nm!

- The filling procedure for the glycerine chambers (K1) and (K2) is specified in section 8.3 "Glycerine filling" below.
- After connecting the metering lines, start the pump as described in section 7 "Startup".
- If the diaphragm should wear out unusually often, please find out why. You may find the reason in section 9 "Troubleshooting".

8.3 Glycerine filling

Note: It is absolutely necessary to keep to the indicated filling quantities when filling the chambers with glycerine!

Please use glycerine 86.5-87% distilled according to DAB 9.

Filling quantities in ml

Pump size	Chamber1	Chamber 2
GMR 2000	850 ml	200 ml
GMR 3000	1300 ml	200 ml
GMR 4000	1300 ml	200 ml

- The rear chamber (K2) can be filled after unscrewing the venting plug.
- For filling the front glycerine chamber (K1) the working diaphragm is brought into rear end position first. For this purpose the fan wheel is turned by hand. The position of the diaphragm can easily be made out on the upper side if the plug is unscrewed. 3. After filling the glycerine, the working diaphragm is slowly moved towards the front side by further turning the motor fan wheel until the glycerine comes out of the filling hole.

Note: If no glycerine runs over at the filling hole, do not continue filling up glycerine anymore, because this means that the front diaphragm is bulged out towards the front so that the chamber volume is increased. In this case you have to move the working diaphragm back (turn the fan wheel), fill the metering head with medium or water so that the metering diaphragm gets back to its original shape. Then you can move the working diaphragm towards the front by turning the fan wheel until the glycerine comes out of the filling hole.

4. Now you can screw in the closing plug and mount the venting plug.

Note:

- It is very important for a correct function of the system to carry out the filling procedure carefully.
- Under normal operating conditions it is not necessary to check the filling quantity. In the case of a leakage in the glycerine system, the same filling procedure as described above has to be carried out. Under no circumstances you should unscrew one of the glycerine chamber plugs during operation or if the system is under pressure.

If glycerine starts running over, close chamber.

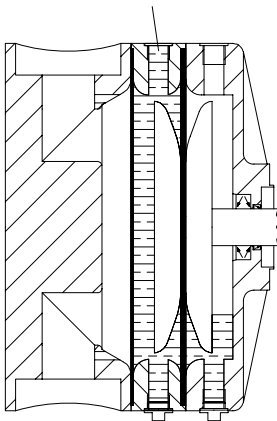

Move diaphragm slowly by hand towards the front end position until glycerine escapes bubble-free.

Make sure that no bubbles are formed when filling this chamber (K1).

Glycerine in this chamber (K2) serves only to lubricate working diaphragm.

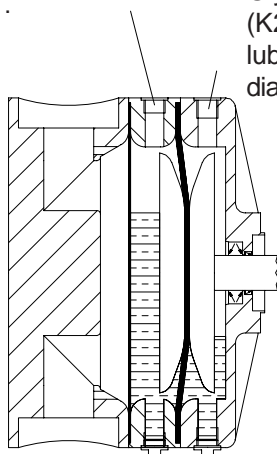

Move diaphragm by hand towards rear end position. Then fill in glycerine.

8.4 Belt adjusting gear

The following explanations refer to the belt adjusting drive with flanged three-phase motor and manual speed adjustment. The electrical adjustment system is described in section 8.5 >Electrical servo-motor ATE<.

8.4.1 Functional description

An adjustable belt pulley is mounted to the drive motor and a spring-loaded belt pulley to the driving shaft of the pump gear. For adjusting the speed, the active diameter at the belt pulley is changed by axially moving the adjustment pulley. For the manual adjustment the handwheel is used. In the case of the electrical adjustment system a spindle is moved by means of a servomotor. Make sure that the belt drive is adjusted only when the motor is running. If electrical remote adjustment is provided, interlock this by means of a drive motor contactor. Regarding the active diameter the spring-loaded belt pulley adapts itself automatically. The belt pulley guides are provided with a permanent grease lubrication, thus there is no relubrication. The adjusting gear must occasionally be operated through all the settings in order to remoisten the guideways with a film of grease. A dusty environment causes a higher belt wearing. Therefore the louvres should be provided with a dust filter.

8.4.2 Resetting of the indicator

After transport or repair of the GMR the indicator at the handwheel has to be checked. For this purpose the top speed and thus the maximum output is set by moving the handwheel to the right-hand stop. The indicated value should now be 100%. If not, slacken the clamping screw at the circumference of the handwheel, rotate the indicator to the correct position and retighten the screw. Afterwards the adjusting gear can be operated through all the settings in order to ensure a correct adjustment.

8.4.3 V-belt exchange

The upper cover of the adjustment gear including the mechanical or electrical adjustment are removed by slackening the 4 cylinder head screws at the circumference of the housing. Now the torn V-belt can be taken off. The new V-belt is first layed around the opened belt pulley and then pulled by hand into the spring washer. Never use sharp-edged tools as the guideways of the belt pulleys and driving belts might be damaged. As new V-belts still lengthen in the beginning the full adjusting range is only reached after a few operating hours.

8.5 Electrical servo-motor ATE

The electrical remote adjusting drive with reversible three-phase motor is stopped in the limit positions by means of limit switches. When being supplied the ATE servo-motor is matched to the adjusting range of the belt drive. After exchanging the driving belts for maintenance reasons or for limiting the minimum or maximum speed, the limit switch cams can be adjusted. The drawing below shows the adjusting possibilities.

For reducing the adjusting range, slacken the locking screw and turn the switch cam for the upper end position in " + " direction and the switch cam for the lower end position in " - " direction. For increasing the adjusting range, turn the switch cams in the opposite directions. Consider that the minimum speed of 550/min corresponding to approx. 11 strokes/min and the maximum speed of 3,600/min corresponding to approx. 72 strokes/min represent the absolute limits.

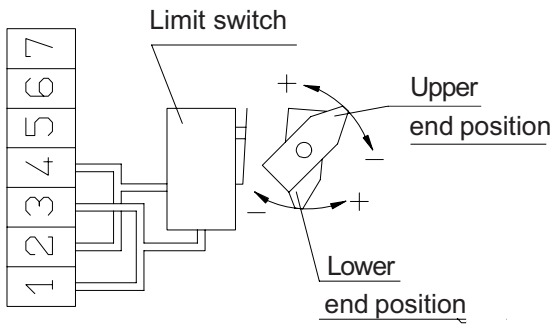

Technical data ATE (type EMFST):

Motor voltage:	230/400V, 50Hz
Nominal current:	0.54/0.31A
Power:	65W
Position feedback:	Poti 2.2kOhm, 0.15W

Wiring diagram for electrical servo-motor ATE

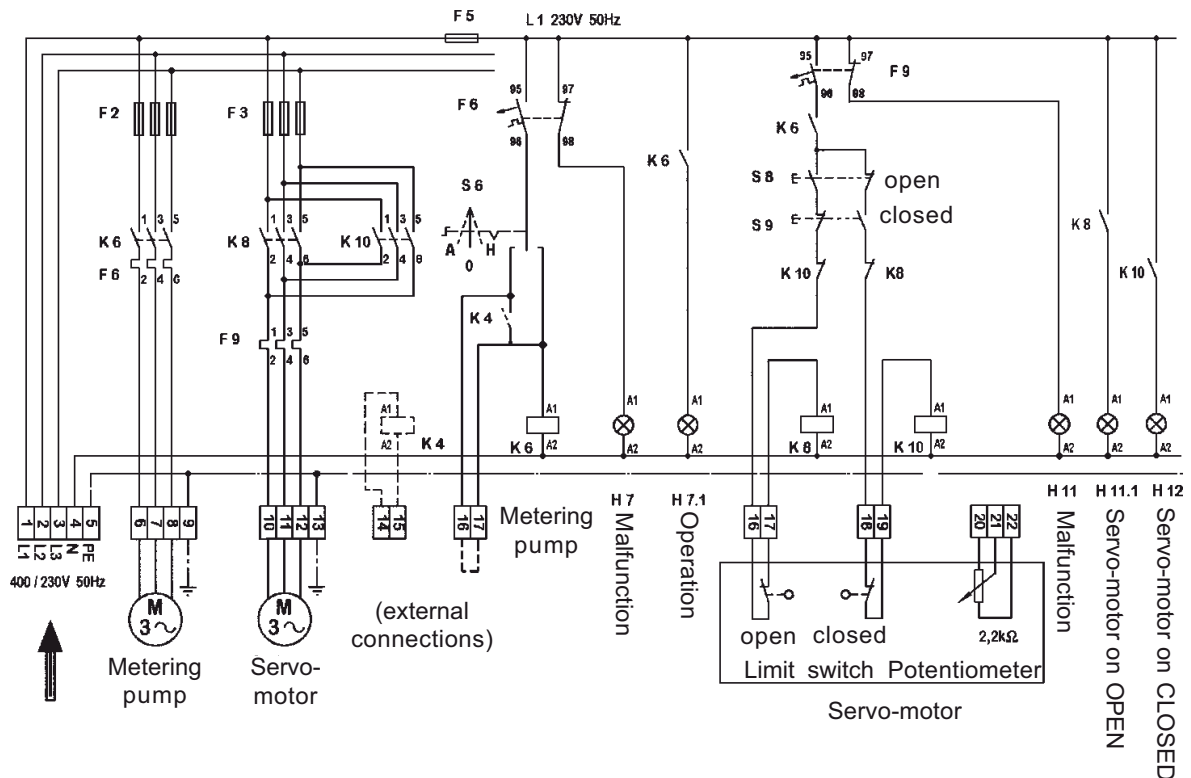

9. Troubleshooting

Type of fault	Possible cause	Recommended action
Pump not delivering.	Valves leaking.	Clean and bleed.
	Valves incorrectly.	Reassemble valves making sure that the valve balls of the suction and discharge valves are located above the valve seats. Clean and seal suction line.
Pump delivering too little or irregularly.	Valves blocked or leaking.	Clean and reseal valves, if necessary fit new valve balls and seats.
	Handwheel has come loose	Secure handwheel.
	Air in glycerine chamber	Bleed, if necessary top up.
Pump delivering too much.	Pressure on suction side too high (pump syphoning)	Fit pressure boosting valve in discharge line.
	Handwheel shifted.	Check and correct.
Pump making loud noises.	Roller bearings running without grease.	Replace motor roller bearings.
	Gear seized.	Dismantle gear and replace defective parts.
Motor humming and will not start.	Incorrect connection.	Check electrical system.
	Pressure too high.	Check operating data.
Motor running, but no output.	V-belt cracked.	Replace V-belt.
	Pump has air in metering head.	Relief discharge line (e.g. open pressure relief valves for a short time.

If the faults cannot be removed with the above data, return the pump to the factory or contact our technical sales department for further measures to be taken. A prompt repair is guaranteed.