

**General**

FLOWCON TS is a thermoelectronic flow controller for continuous and pulsating flow of metering pumps. The pulse frequency should not be lower than 50 per minute, because otherwise the interval would be signaled as a metering failure. The design of the enclosure allows to control even smallest flow rates of  $\geq 0.1$  l/h. As FLOWCON TS also works with continuous flow, the flow rate can be monitored directly at the injection point just before the process entry.

A flow-dependent difference in temperature between two sensors is the measure for the flow rate. Using the thermal effect causes a small delay ranging from 30 seconds for the PTFE version and a few seconds for the stainless steel version.

For power supply, a mains unit with switching relay is used or e.g. an SPS (PLC) provided by the customer, which replaces the mains unit.

**Technical data**

Material	Sensor	PTFE
	Sensor	1.4571
Setting range	continuous	0.1...150 l/h
	pulsating > 50min-1	0.5...50 l/h
Medium temperature	*1	-25...+80°C
Max. viscosity	*2	5000 mPa*s
Max. pressure	PTFE	5bar
	1.4571	10bar
Response time	PTFE	2...20s
	1.4571	1...10s
Operating voltage		20...36 V DC
Current load		max. 400mA
Current consumption		max. 45mA
Display w. LED chain at sensor		11 LED
Ambient temperature *1		-20...+80°C
Delay until ready		up to 20s
Protection class		IP67
Connection		M12 plug
Switch point setting		Poti

- \*1 applies to sensors and PVDF fittings only.  
For PVC fittings, the max. temperature is 45°C.
- \*2 applies to up to 50 l/h for continuous flow and up to 20 l/h for pulsating flow.

**Selection table**

Description	Material	Part No.
<b>Sensor ST0521 ST2609</b>	PTFE	79067
	1.4571	79068
<b>Fittings</b>	PVC / Viton	35201
	PVDF / EPDM	35202
<b>Complete device</b> Sensor / fitting Plug with 2m cable	PTFE / PVC	13335194
	1.4571 / PVDF	13335195
<b>Cable</b> Plug with 2m cable Plug with 5m cable Plug only	E 40023	79070
	E 40024	79071
	E 10012	79072
<b>Power supply</b> prim. 230V, 47/63Hz sec...24V DC für Sensor Switching relay, 250V, 8A AC, max. 1250VA	DN 0001	79069

Dimensions

Sensor

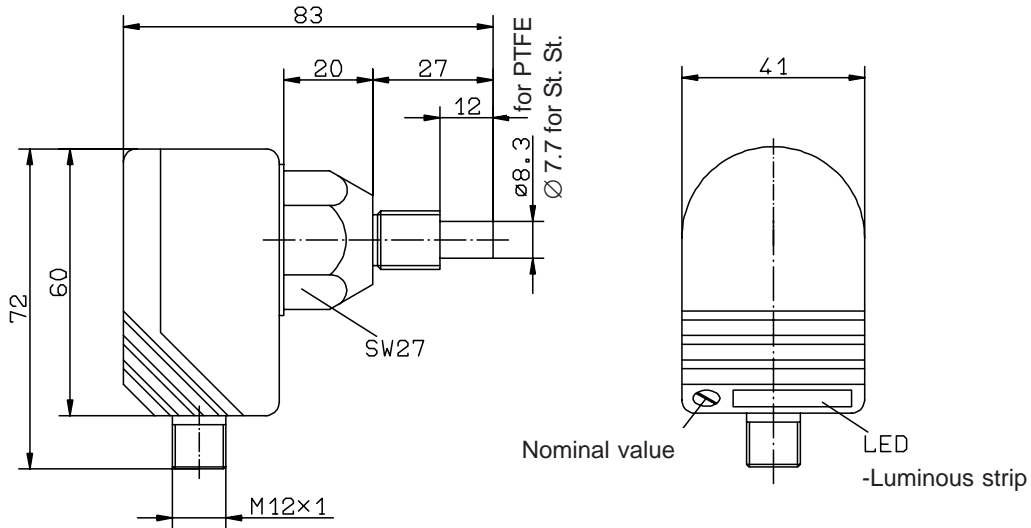

Plug connection for cable extension

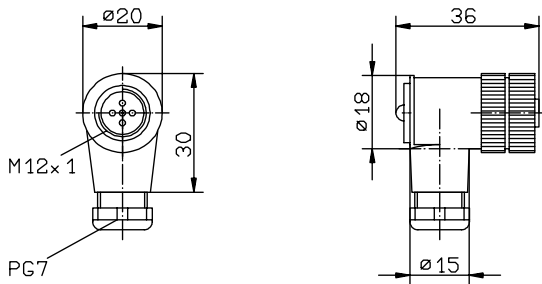

Plug connection with 2m or 5m cable

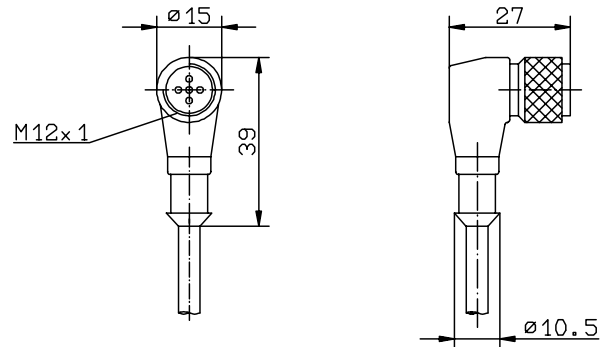

FLOWCON TS assembly

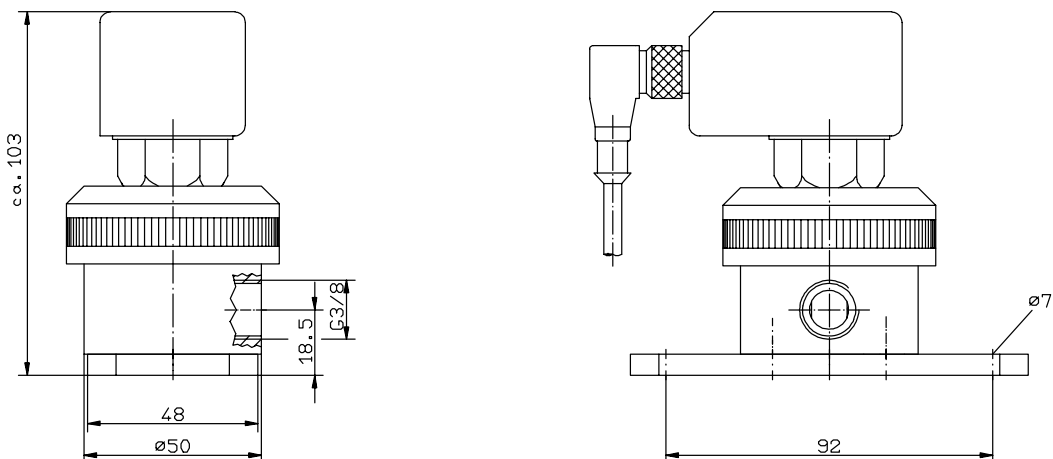

Power supply

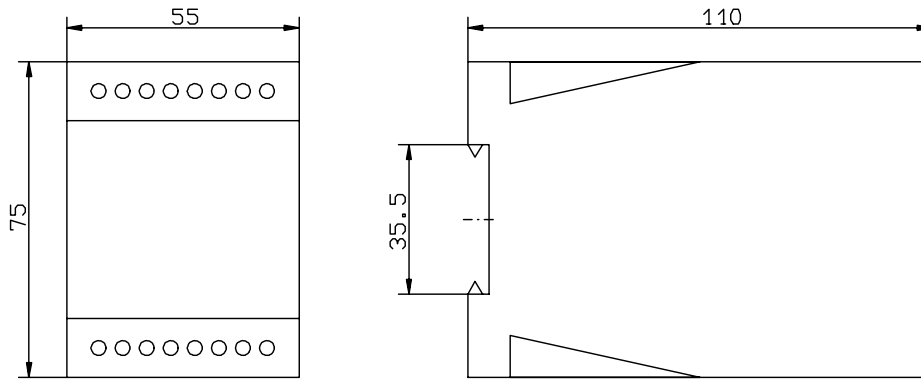

Selection table for connections

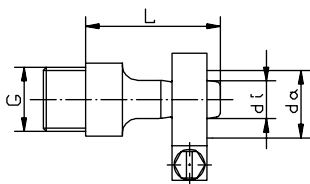

Fig. A  
Tubing connection

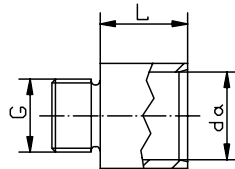

Fig. B  
Cemented pipe connection

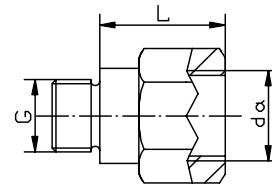

Fig. C  
Threaded connection

Connection G	DN	Line connection			PVC		St. St.	
		L	di	da	Fig. B	Fig. B	Fig. A	Fig. C
G 3/8	10	35	9	15	32462	—	—	—
		32	9	15	—	—	26500	—
		18	—	12	—	82901	—	—
		18	—	16	—	82902	—	—
		18	—	20	—	82900	—	—
		28	—	G 1/2	—	—	82956	

### Installation

The **FLOWCON TS** can be mounted in any position. The flow direction must, however, be taken into account. Depending on the connection, self supporting inline installation of the **FLOWCON TS** is possible (for this purpose, it might be sensible to remove the base) but it can also be mounted on tanks or fixed to the wall (with base). In every case, make sure that the display is easily legible and accessible.

We recommend to install the electronic evaluation unit with power supply in a switch cabinet. For distances up to 2 or 5 m, standard cables with plug are available. In the case of longer distances (must not exceed 50 m), only use the plug and lay an appropriate cable without interruption. Avoid to lay cables in parallel to the power lines because of electrical interferences.

Depending on the required switching function (PNP or NPN, i.e.: the contact is either closed or open in the green nominal range), wiring must be carried out correspondingly. See wiring diagrams below.

Power supply and evaluation can be done by an SPS (PLC) provided by the customer so that the electronic evaluation unit is not required.

### Startup

To commission and set the **FLOWCON TS** vent the line, adjust the desired flow rate and switch on the power supply so that the **FLOWCON TS** is provided with the operating voltage. At this time it is unimportant which

LED lights at the **FLOWCON TS**. Depending on the length of the metering line, the flow rate should be maintained at the desired value for some minutes to make sure that there are no irregularities at the measuring point due to e.g. air bubbles. If the operating condition is stable, turn the nominal value screw using the supplied screw driver, until the green LED next to the yellow one lights up. The closer the green lit LED is to the yellow LED which represents the transition to the switching point, the earlier switching takes place in the case of reduced flow rate. The same applies to the red LED row. The very left red LED indicates the lowest flow rate compared to the nominal value.

Note: The sensitivity of the sensor is highest at its cone end, i.e.: even slight deviations from the nominal flow rate cause switching. In any case switching takes place if the flow is interrupted.

### Maintenance

No maintenance is required as far as the electric part is concerned.

Regarding the hydraulic part, deposits and obstructions might result in malfunction, i.e.: reduced flow will be signaled although it may be still in the admissible range. It would be sufficient to adjust the switching point. It is, however, recommended to open the fitting after stopping metering, switching off the power supply and observing the local safety rules, and to clean the sensor and the fitting itself. Never apply hard subjects to the sensor.

### Wiring diagram

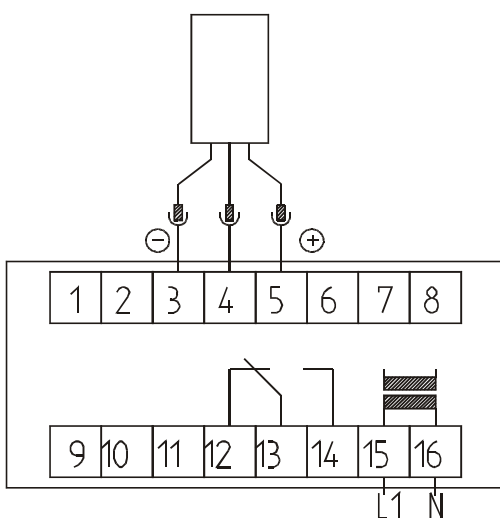

Wiring diagram for power supply

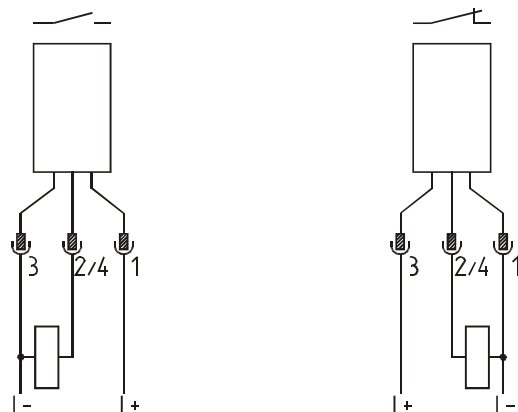

Wiring diagram for sensor